

University of Minnesota-Twin Cities and MN Space Grant Consortium

# AEM 1301 Freshman Seminar: Fall 2021

## Introduction to Spaceflight (With Stratospheric Balloon Project)

### Team Project Documentation

#### *The Pyramid of Light*



Written by:

Ethan Jannsen, Kenny McAndrews, Ty Flanagan, Owen Olson, Nick Gardner

11/05/2021

Revision B

## Table of Contents:

0.0	Team Member Assignments.....	3
1.0	Introduction.....	4
2.0	Mission Overview.....	5
3.0	Payload Design.....	6
4.0	Project Management and Schedule.....	11
5.0	Project Budgets.....	14
6.0	Payload Photographs.....	15
7.0	Pre-Flight Ground Testing Plan and Results.....	17
8.0	Expected Science Results.....	21
9.0	Flight Day Narrative.....	24
10.0	Results and Analysis.....	28
11.0	Conclusions and Lessons Learned.....	61
12.0	References.....	62
13.0	Appendix: Program Listings.....	63

## 0.0 Team Project Documentation Writing/Build/Flight Day Assignments

Team Name: The Pyramid of Light

Introduction: Ethan J.

Mission Overview: Ty F.

Payload Design: Owen O.

Project Management: Kenny M.

Project Budgets: Nick G.

Payload Photographs: Ethan J.

Test Plan and Results: Ty F.

Expected Science Results: Owen O.

Flight Day Narrative: Kenny M.

Results and Analysis: Nick G., Owen O., Ethan J., Ty F., and Kenny M.

Conclusions and Lessons Learned: Ty F.

References: Ty F. and Owen O.

Program Listings: Nick G., Owen O. and Kenny M.

### Oral Presentation Assignments

Conceptual Design Review (CDR): Nick G. and Ethan J.

Flight Readiness Review (FRR): Ty F. and Owen O.

### Payload Build Assignments

Overall team lead and ground-testing lead: Kenny M.

Payload box build: Owen O.

PTERODACTYL basic sensor suite: Ty F.

Programmer lead for the PTERODACTYL: Nick G.

Camera experiment: Ethan J.

Neulog modules (including set-up): Kenny M.

“Other” science experiment(s): Ty F.

### Flight Day Assignments

Documentation/photographer: Ethan J.

Flight prediction specialist: Kenny M.

Payload handling/start-up specialist: Owen O.

Comms telemetry data specialist: Nick G.

Payload telemetry data specialist: Ty F.

Aprs tracking specialist: Ethan J.

SPOT tracking specialist: Kenny M.

## 1.0 Introduction

For many the dream of launching a payload into space is unobtainable due to the high cost and amount of time required to create something that can be safely launched and possibly return to earth. That is why many enthusiasts have found other ways of achieving near-space flight for the fraction of the cost and time that a chemical rocket would take to design and build. The most popular method of achieving near-space (approximately 100,000ft) flight for enthusiasts of spacelight is using latex weather balloons filled with helium or hydrogen gas. This is as the cost of buying one of these balloons and payloads is only a few hundred dollars at minimum instead of the millions required to get the same payload past the Karman line (330,000ft) and into outer space.

Generally for most amateur balloon flights, the costs range from 500USD-2,000USD depending on what your payload consists of and other factors. The reason for the large range in the cost is because many who launch these balloons try to capture lots of scientific data that can only be gathered at high altitude. This is why many bring Geiger counters, temperature sensors, light sensors, barometers, cameras of various kinds, telemetry and more to learn more about their planet by their own means.

Ultimately since the invention of high altitude balloons in the early 20th century a whole new world was opened to the general public who had an interest in space and the passion for the unknown. That passion still lives on today with high altitude ballooning becoming the most popular way for enthusiasts to bring payload into near space atmospheric conditions.

## 2.0 Mission Overview

Our main goal is to measure the properties of solar energy up to and in a near-space environment using two solar panels. We also will be measuring contextual information, recording video, and using an infrared camera. To do all of this we need to keep our box protected from the near-space environment, point our solar panels towards the sun, and keep our data instruments running.

To protect our payload from the environment, mainly the cold, we will make the outside of the box completely black as to help absorb more solar heat during the flight. Additionally we will be using insulating Styrofoam as well as hand warmers inside the box. To point our solar panels towards the sun, we have angled them 27.55 degrees up. According to the NOAA Solar Calculator, the sun will be between 25 degrees climbing to 30 degrees above the horizon around midday on October 30, 2021. 27.55 degrees should be a good middle ground for the flight duration. To keep our data collection running we mainly have to just worry about the cold and battery life. Both of these are planned to be fixed by using large batteries that have worked in the past, the use of hand warmers zip tied to batteries, and insulation.

For the light experiment we will be using two solar panels mounted on opposite viewing sides. Both will be connected to their own voltage and current Neulog modules. Some of the questions we hope to answer include how much energy can be gained from the sun, how strong of a difference is there facing the sun vs not, and how voltage and current from the panels change as the balloon climbs into near-space, going through the different layers of the atmosphere. For contextual information such as orientation, direction of sun, temperature, altitude, time since bootup, and pressure we will be using a Neulog pressure module, data gathered from our sister team, and a PTERODACTYL. This contextual information will be useful when making sense of what our solar panel data means and give us a general idea of the happenings of the flight, especially the time since bootup from the PTERODACTYL and pressure from both the Neulog and PTERODACTYL. For recording video we will be using a Lightdow camera due to its long life span and reliability. This recording will also give us potential contextual information and simply will be interesting to watch back. Lastly, for our infrared camera, we plan on pointing it towards the other payload and our balloon. This hopefully will give us a good view of the infrared light coming off of the payload and balloon as we climb into near-space.

### 3.0 Payload Design

When designing our payload, there were very few requirements that needed to be met. In reality, there were only a few baseline functions our payload had to be able to complete throughout its entire flight, since price is not a factor. Firstly, it had to contain a PTERODACTYL control board along with GPS, IMU, thermistor, pressure sensor, and onboard radio transmitter. This would function as our communication with the payload throughout its flight. Along with this, an externally attached IR sensor needs to be wired in, with the placement of the unit up to the team. Secondly, there must be a camera on the flight as well. This requirement is a little more lenient since between the two payloads, there must be two cameras. It is up to the teams to determine if one payload has two cameras, or both have one. Lastly, you need a Neulog chain gathering information during the flight to fulfill the mission objective. These Neulogs come in a variety of types, and it is up to the team to determine which ones best fit with the questions they set out to answer. These three things are truly the only requirements for the payload. As for limitations, there's only a few as well. The largest restriction is the weight. Between the two payloads, a combined weight of 5lbs is the maximum number we can reach. Simply speaking, we have to build the payload under two and a half pounds. Secondly, we can only have a maximum quantity of 5 Neulog sensors, excluding the battery, within our payload. This is mostly based on the ability of one battery being able to power only 5 Neulog sensors, but weight is also another factor when determining this. Lastly, one of the sensors in that chain must be a pressure sensor. Even though the PTERODACTYL has an onboard pressure sensor, it lacks accuracy, and pressure is the easiest way to determine the flight of the payload (pressure decreases as you go up, so you can determine altitude using that data), with the most accurate reading possible.

With these requirements and limitations, we were able to design a payload: The Pyramid of Light. As for the components, it contains a PTERODACTYL and it's likewise built-in sensors along with a wired in IR sensor, one 9 volt battery, two voltage Neulogs, two current Neulogs, one pressure Neulog, one Neulog battery, one lightdow camera and external battery, and two solar panels. The PTERODACTYL will give us real time readings from the flight for location purposes, which will be powered by the 9 volt battery. This is not the most precise reading, however, so the SatCom will provide us with the most precise coordinates of the Payload throughout its flight. The IR sensor wired through the PTERODACTYL will be pointed upwards towards the other payload, as well as the balloon. The two voltage and current Neulogs in our chain will monitor circuits connected to the solar panels throughout the flight, allowing us to see the change in efficiency as we gain altitude. The pressure Neulog will of course give us pressure values throughout the flight. The whole Neulog chain will then be powered by the Neulog battery.

### 3.1 Parts List

#### Structural Components:

- Styrofoam
- Rigging tubes
- Strapping tape
- Duct tape
- Braided mason twine
- Key rings

#### PTERODACTYL and Subsequent Sensors:

- PTERODACTYL Control Board
- Teensy 3.5
- Usb 3 way cable
- 9 volt battery snap
- 8 gig micro sd card
- L7805CV 5V voltage regulator
- Ublox m8n gps
- LSM9051 9DOF IMU
- Thermistor
- Resistor
- Ms5611 pressure sensor
- 0 led screen
- Xbee 3 radio
- Xbee breakout board
- LED
- Male to male jumper wires
- Male to female extender wires
- Battery jack
- Male header strip
- Female header strip
- 2 position terminal blocks
- 8 position terminal blocks
- Shorting plugs

#### Neulog Modules:

- Battery module
- USB extender cable
- Voltage Module x2
- Current Module x2
- Solar Panels x2 (Subcategory of Voltage and Current Sensors)
- Pressure Module

#### Camera/Accessories:

- LightDow Camera
- Anker battery pack
- 32 Gigabyte Micro SD Card

### 3.2 Functional Block Diagram

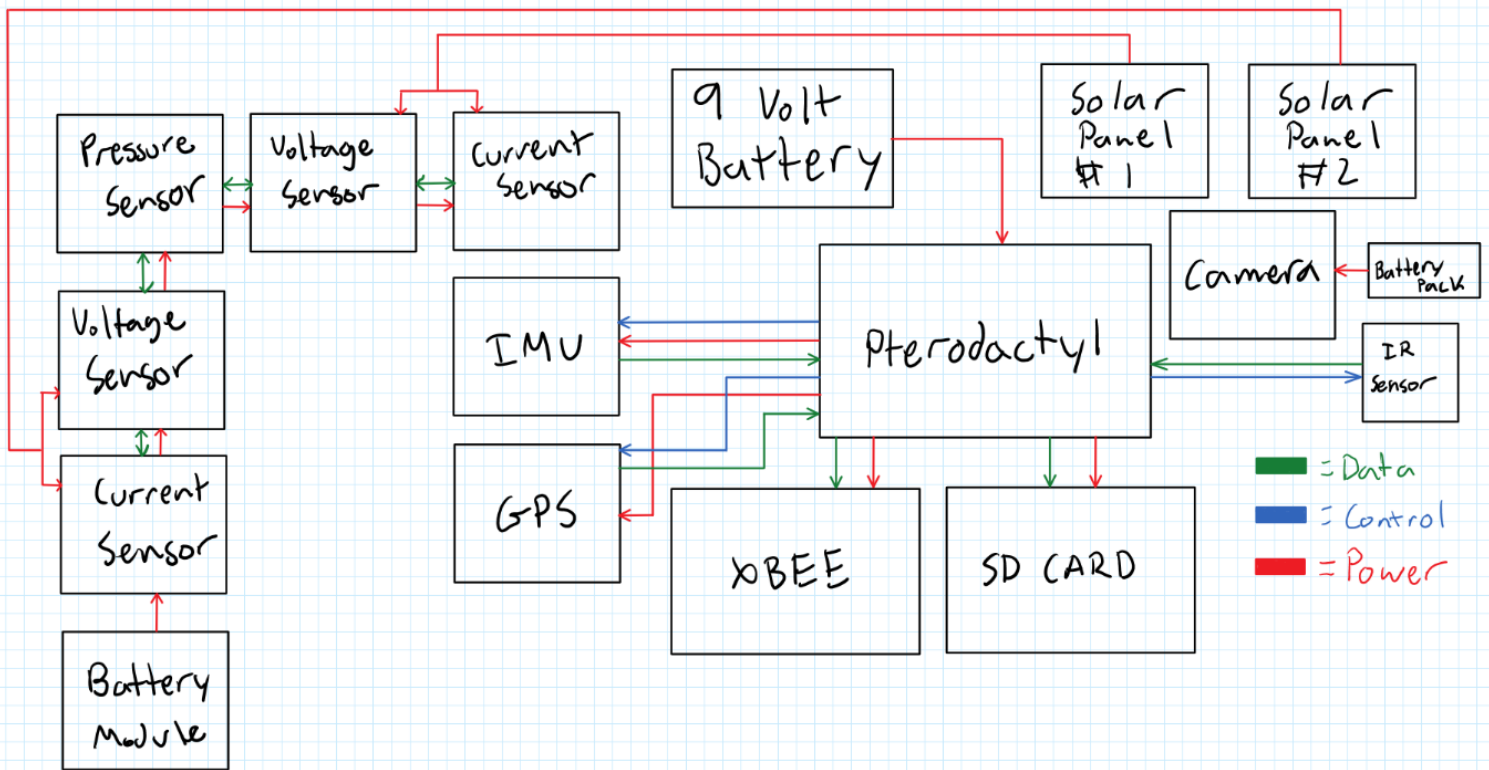

Above is a complete wiring diagram of the sensors and electronics within our payload. To the side is a more in-depth look at a wiring of a single solar panel circuit, containing the load (resistor) within the circuit, as well as the two Neulog modules collecting the data

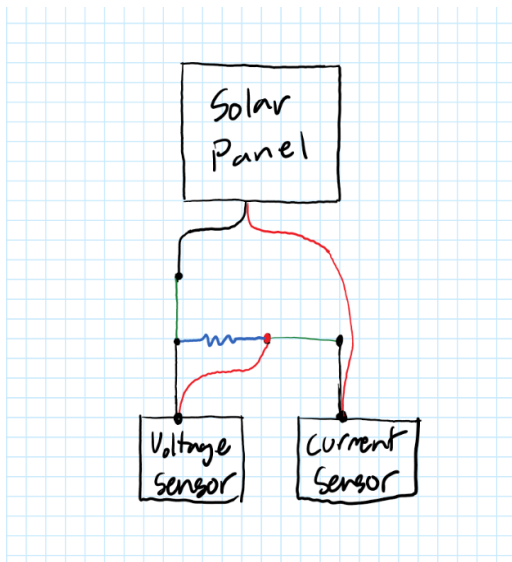

Circuit Diagram. Energy is collected from the solar panels and then is split into a parallel circuit between the voltage and current sensors with a resistor bridging the two.



### 3.3 CAD Drawings

- 1) PTERODACTYL - Main board running multiple wired sensors including GPS, IMU, thermistor, pressure sensor, and onboard radio transmitter, as well an externally attached IR Sensor.
- 2) 9 Volt Battery - Power for the PTERODACTYL and its sensors.
- 3) Window - Allows the ground crew to see if the PTERODACTYL is running after the box is closed. This is done by monitoring the LEDs attached to the PTERODACTYL.
- 4) Switch - This switch is an external power switch for the PTERODACTYL, allowing us to turn on and off the module after the box is secured shut, if need be.
- 5) Neulog Chain 1 - This is the first set of 3 Neulog sensors in the chain of 6. This includes one pressure module, one voltage module, and one current module.
- 6) Neulog Chain 2 - This is the second set of Neulog sensors in the chain of six. It includes one voltage module, one current module, and one battery module. This side of the chain will power the whole chain of six, which is connected by a cable located at the apex of the pyramid.
- 7) Lightdow Camera - This camera is positioned in the box to be looking outward and down throughout the flight, and was chosen specifically for its long term battery life.
- 8) Anker Battery Pack - This is the key to the Camera's extended battery life, and allows us to get the full flight in one charge.
- 9) IR Sensor (110 Degree Angle) - This infrared radiation sensor is located on the top of our payload. This means it will be pointed at not only the payloads above ours, but the balloon as well, giving a wide range of values and subsequent information. In our case, however, we chose to look at one single point in its 110 degree view for simplicity.
- 10) These two solar panels will be the focus of our entire flight. Each panel will be hooked up to a circuit that will be monitored by the voltage and current Neulog modules. This will provide us data on the efficiency of the solar panels as they travel through their flight.
- 11) The solar panels are faced in opposite directions to allow us to gather information throughout the entire flight, even if the payload spins as it ascends.

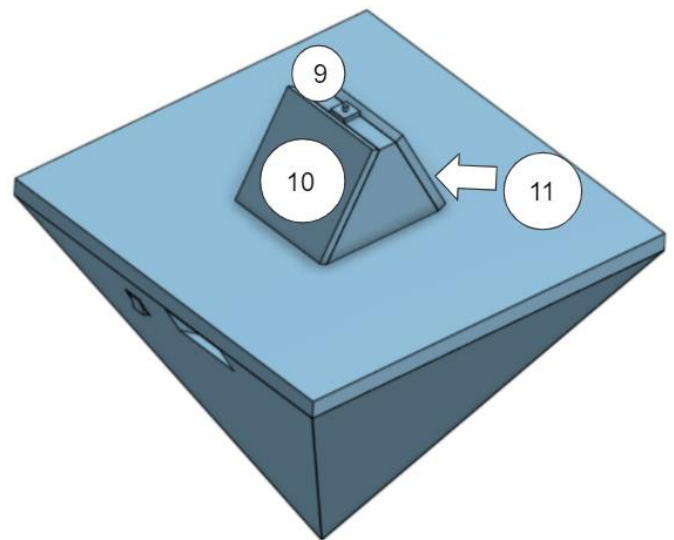
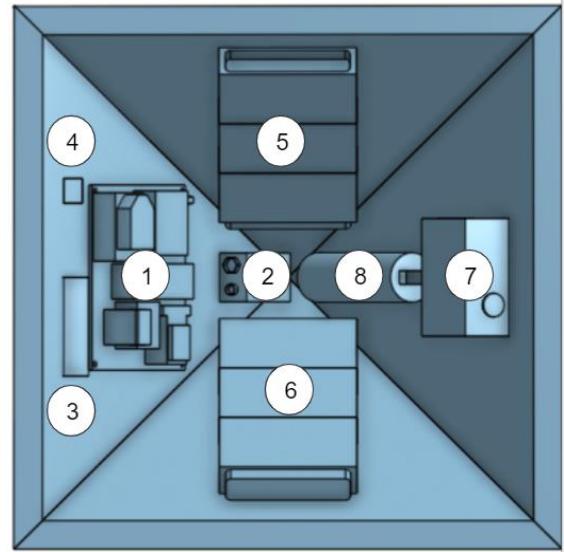

### 3.4 PTERODACTYL Wiring Diagram

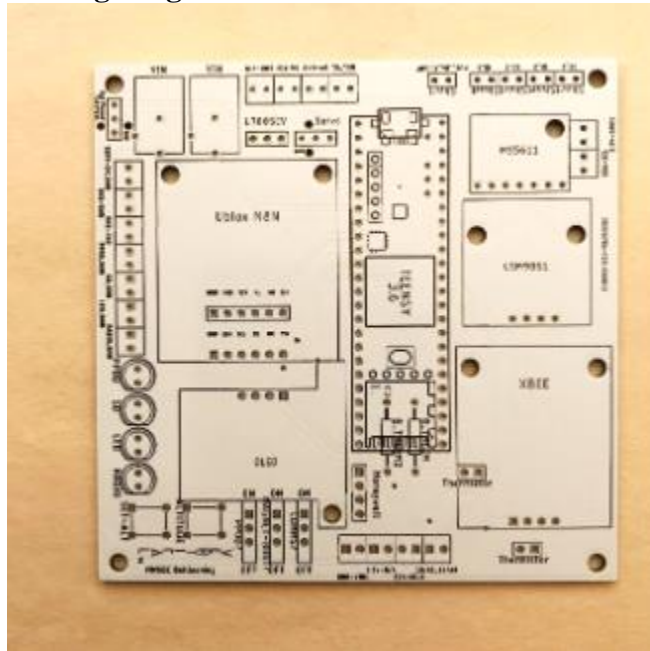

An unpopulated PTERODACTYL custom printed circuit board (pcb).



A populated, and wired, PTERODACTYL. The pair of wires at the top go to an external on and off switch. The pair of wires at the bottom go to the PTERODACTYL external thermistor. The four wires on the right (Ground/black, 3.3V/red, SCL/yellow, SDA/blue) go to the IR camera.

## 4.0 Project Management

Our team organization was initially chosen with very little thought, but as we've learned what each role entails and fitted the right person to the right job, things have gotten more concrete. I believe this section will be heavily edited in the future and so, for the time being, this is only a good estimation of how the team will be divided along with what roles people have already completed.

### Schedule

- Thursday September 30.
  - Meet to discuss our proposal
  - Assign who does what part of the presentation
- Tuesday October 5.
  - Proposal/Conceptual Design Reviews(CDR) due
  - Discuss any changes that need to be made
  - Work with other job to negotiate who will take what sensors and cameras
- Tuesday October 12.
  - Begin construction
  - Test PTERODACTYL
  - Work on Rev A
- Friday October 15.
  - Rev A due
- Tuesday October 19.
  - Flight prediction software
  - launch/tracking/recovery logistics
  - remote monitoring logistics
  - Some class time to work on FRR and/or construction, integration, and testing
- Tuesday October 26.
  - Flight Readiness Reviews (FRR) due
  - Some class time to finalize payloads
  - payload weigh-in/turn-in (if finished)
- Thursday October 28.
  - Final deadline for weigh in/turn-in
- Saturday October 30.
  - LAUNCH DAY
  - Alternate days include Oct. 31, Nov. 6, or Nov. 7
- Tuesday November 2.
  - Some class time for data extraction from payloads
  - data analysis tips
  - preliminary data analysis
  - Introduction to Peer Reviewed Essay Assignment
  - select partners and divide essay topics
  - Past-looking details about eclipse ballooning
  
- Friday November 5.

- Rev B due
- Tuesday November 16.
  - Some class time to continue work on data analysis and generate data analysis visuals/graphs
- Tuesday November 23.
  - Feedback offered on data analysis visuals/graphs
  - Some class time to work on Rev. C
- Friday December 3.
  - Team Project Documentation –Rev C: All sections due 5 p.m.
- Tuesday, Dec. 7
  - Some class time to prepare for end-of-semester post-flight video (~5 min) and public exhibit
- Tuesday, Dec. 14
  - Watch post-flight videos in class.
  - End-of-semester public exhibit

### 4.1 Team Organization Chart

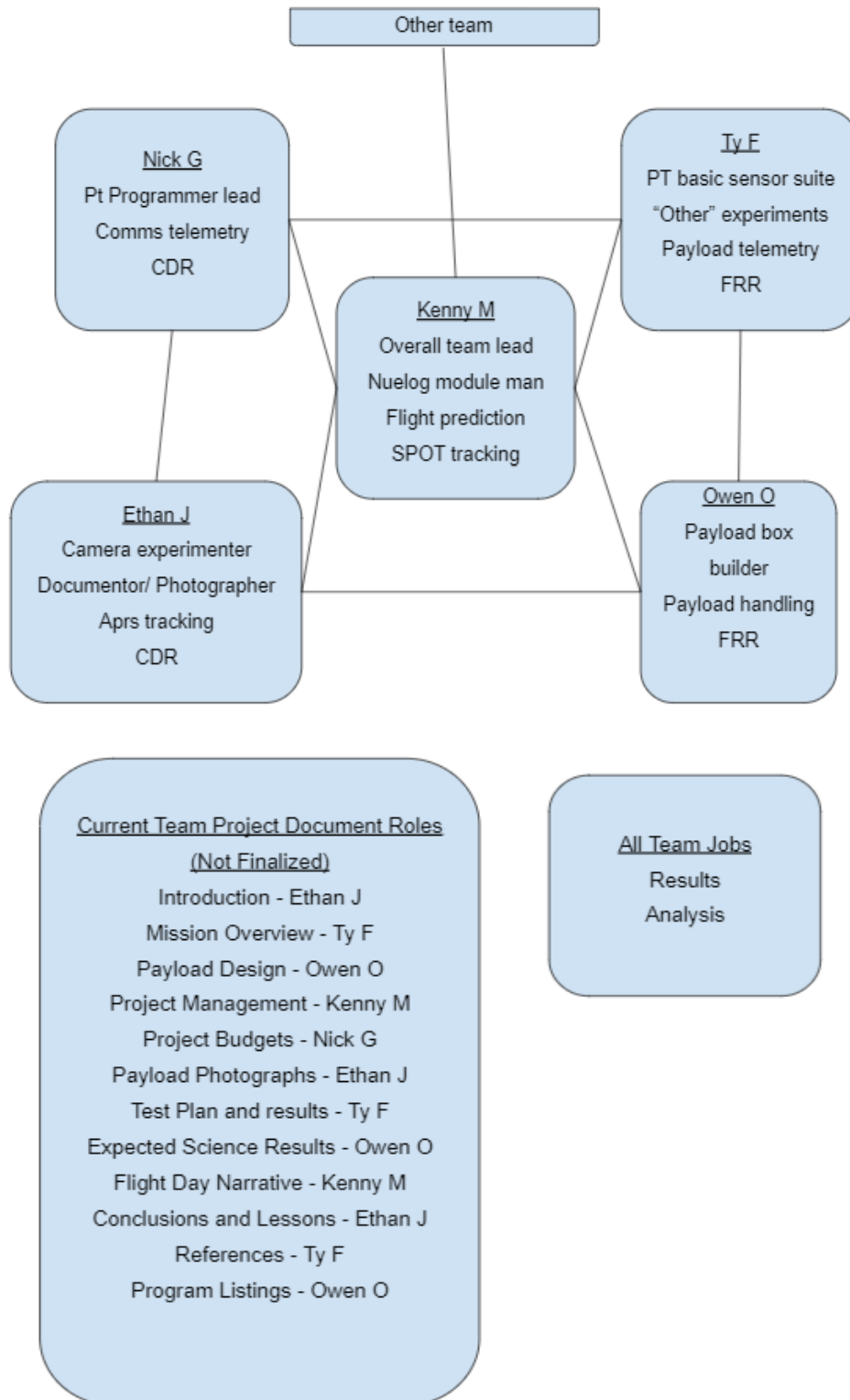

### 5.0 Mass Budget Estimate

Component Section Masses	Weight (oz)
Structure	15.9
PTERODACTYL	5.2
Neulog Sensors	11.4
Camera + Misc	6.73
Total Estimated Mass	39.23

### 5.1 Money Budget Estimate

Money Budget	Cost (\$ in USD)
Structure	\$28
PTERODACTYL	\$200
Neulog Sensors	\$287
Camera + Misc	\$84.74
Total Cost	\$599.74

### 5.2 Actual Total Weight Readout

Actual Final Weight Before Rigging	34oz
Actual Final Weight After Rigging	40.05oz

## 6.0 Payload Photographs



This is a picture of the completed payload from an isometric view. It is freshly coated in black duct tape, the solar panels are secured, and the rigging is applied. The module on top includes a solar panel on each side as well as an infrared sensor facing directly upwards towards the other payloads and the balloon.

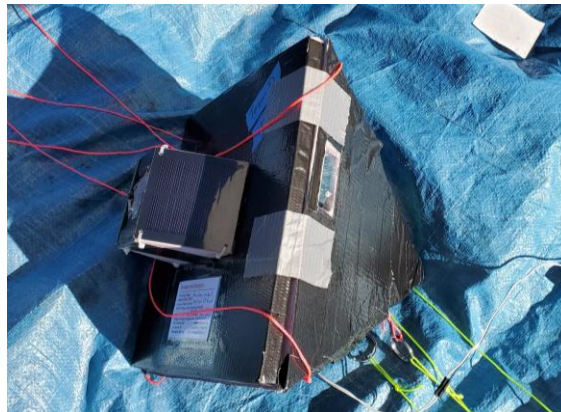

This is a picture of the payload in its final form. The lid is taped down, and the rigging is attached to the payloads above and below it. Everything is powered on and recording data and as far as we knew, everything was working as it should.

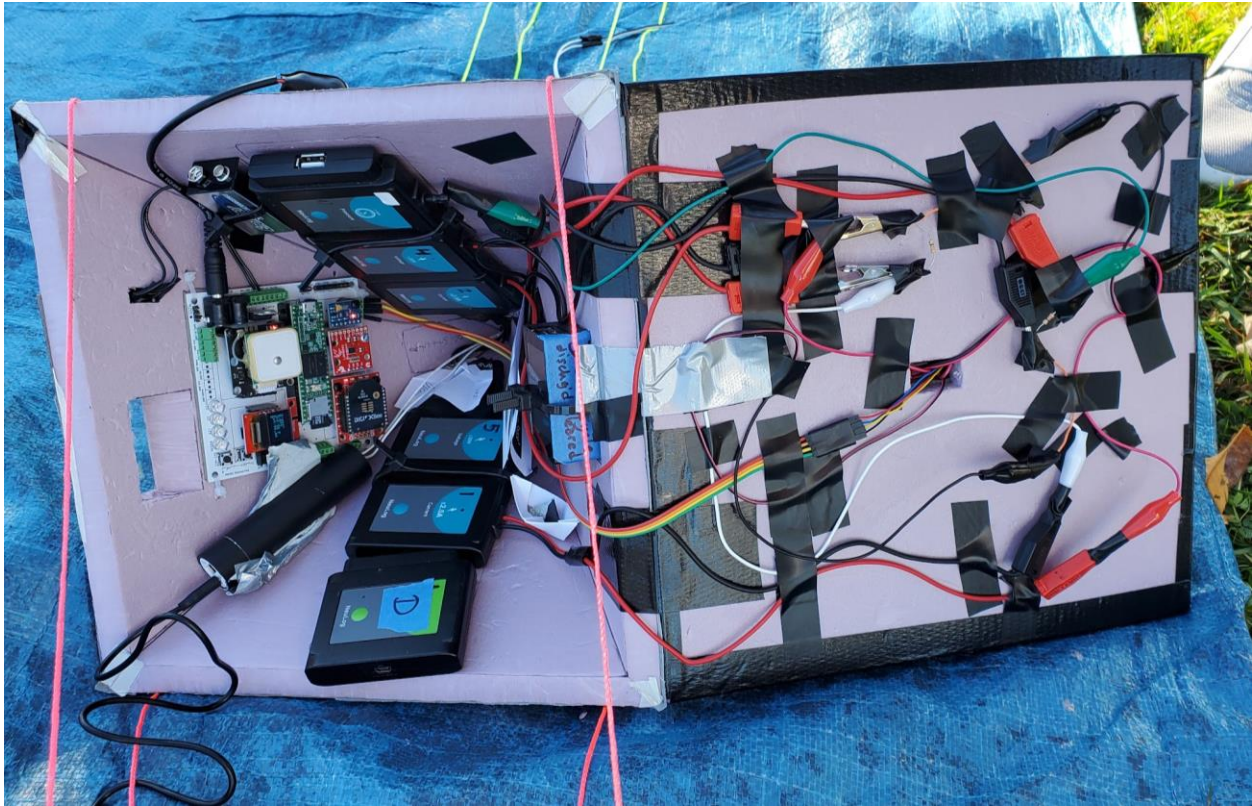

This is a picture of the final internal system and wiring of our payload. On the right is our solar panel circuit. It is powered by the solar panels on the reverse side and consists of a voltage sensor and current sensor for each panel as well as a resistor to allow current to flow. Our Neulogs as pictured on the left are in two chains connected by a USB extender cable in order to fit the shape of our payload. The PTERODACTYL is also ready to go. It is connected to an external thermistor, as well as an infrared QUIIC sensor located on the top. The battery in the bottom left corner will be attached to the LightDow camera.

\*all batteries will be attached to a hand warmer before launch to try to keep them warm.



## 7.0 Pre-flight Ground Testing Plan and Results

The individual parts of our module will be tested by the individuals in charge of them prior to the submission of Rev B, see schedule. Each test should last at least one hour, possibly longer depending on individuals ability to do so, have changing conditions around them to affect the data being collected, and be used with the batteries it will be flown with. For example having light levels change for the solar panels and using the Anker battery pack with the Lightdow Camera. After each test, the data will be collected and checked for measurement errors and as good practice for using the data programs that will be used on the flight data. After each component is tested and verified to be in working condition the final box will be assembled and tested. This will be a team effort and organized around people's availability. This test should also last for at least one hour if not more and again the conditions should change. After this test the data will be collected and read for errors. After every test, problems should be corrected and the part should be retested to make sure the problem is resolved and no new problems arise. This will be especially crucial in the complete payload test. The parts that will be tested include: Neulog modules, solar panel, PTERODACTYL, infrared camera, Lightdow camera, and full payload.

### 7.1 Neulog modules and Solar Panel test:

- In order to ensure that our Neulog modules are gathering data for our entire flight, we will need to do a test that will measure the accuracy and endurance of our modules. The first step in doing this is to build the circuit between the solar panels, current sensors, and voltage sensors. A test will be conducted on the functionality of the circuits by doing a live experiment using the Neulog Experiment program. Once it is confirmed that the sensor-solar panel systems are working, we will begin the test on the modules under battery power. We will begin our battery operated test by connecting all of the Neulog modules (2x voltage, 2x current, and 1x pressure) and their corresponding systems in a chain including the previously fully charged battery. Secondly, we must begin collecting data by pressing the blue button on each module. To make sure that the battery powered data collection is working, we will do an initial five minute data collection interval, plug the chain into the computer and ensure that data was collected. Then we will repeat the process for an interval of an hour to test that the system works over an extended period of time. To be certain that the modules are functioning, it will be necessary to test them in different conditions during the interval of the test so that when we look at the data from the test, there is change. Since our experiment is solar powered, we will start the test in a dark room, move to a dimly lit room, then a brightly lit room, and then outside for 15 minutes in each location. To test pressure, we will simply suck on the sensor briefly in each location. Once the hour long experiment is complete, we will plug the modules into the Neulog software and load the experiment. If the data is properly collected, we will know that the test was successful. If the data is not properly collected, we will need to troubleshoot, and repeat the experiment.

- The testing of the solar panel Neulogs was initially rough as the solar panels did not produce the expected current and voltage values. Voltage stayed consistent throughout every test, but current didn't produce any reading at the beginning. We tried to correct this by using a resistor of  $300\Omega$ . Since current is voltage divided by resistance, using a smaller resistor should have given us a greater current value. After this, we were able to get minute changes in current while in direct sunlight.

- Graphs showing Neulog test results:

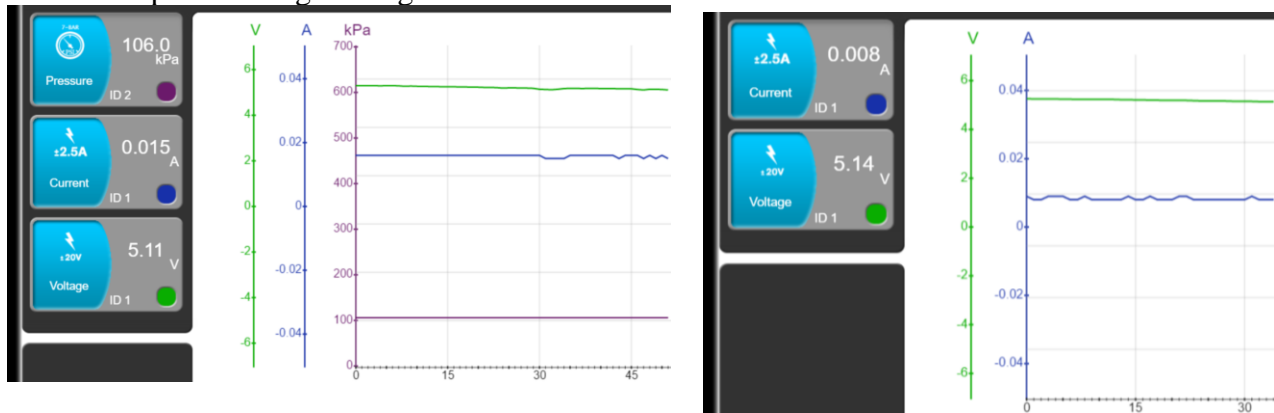

## 7.2 PTERODACTYL Test:

- In order to test and confirm the PTERODACTYL is working properly the provided code must be tweaked to fit our needs. This code must also include the IR camera code. Once the coding is working the test can be done. This test should be at least 1 hour long and have changing conditions so that the forces on the box, temperature, and pressure change throughout the test.
- An individual test of the PTERODACTYL was not completed until the full test of the Payload as a whole. After collaborating with Seyan, the first test did not log any data from our sensors, which was a result of faulty SD card reading. This was promptly fixed, and the second test resulted in all data values being logged and at the correct time intervals.

## 7.3 Infrared Camera Test:

- In order to test and confirm the IR camera is working properly the code must be written and the competent must be tested for at least 1 hour with changing conditions. For the coding we need to find what pixel of the camera's resolution we want to single out for data collection. This code must also be integrated into the PTERODACTYL code so that it is captured within the same system and file. This test can and most likely will be part of the PTERODACTYL test simply as both run on the same code and the IR camera will be wired through the PTERODACTYL.
- Results from this test came back positively, after solving the data logging issue within the PTERODACTYL. It took a decent amount of work to figure out the combination of code

and how to find the right pixel for data collection. In the end, we choose to use a single pixel out of the entire view of the sensor. This was in part due to the complexity of the code, as well as the inability to log such great amounts of data. The testing proved it to be functioning properly, increasing and decreasing the temperature reading during our complete payload test.

#### 7.4 Lightdow Camera Test:

- In order to test and confirm the Lightdow camera's ability to function properly for the whole extent of the balloon flight a test will be conducted to measure its performance. 1. The first step will consist of charging the Lightdow Camera's internal batteries to their maximum, and at the same time charging the Anker external battery to its maximum. 2. After confirming that the two devices' batteries are fully charged they will be connected together and turned on, and during this process it will be confirmed that the camera's settings are properly set up according to the will of the group. 3. After confirming the Lightdow camera is properly turned on, the camera system which includes the external battery will be placed in front of a window during daytime to see the camera's picture quality in an similarly lighted environment and left to run for at least 3 hours per test. 4. After 3 hours have passed, check the battery level of the camera and external battery, and record the amount of battery left in each device and if the camera was able to last for the entirety of the experiment. 5. Repeat as many times as needed.
- Results from the camera tests showed it to be functioning properly. Both the picture and video options of the camera were tested, and both seemed to log the images on the SD card, and were able to be viewed on a separate device.
  - Picture from Test:



### 7.5 Full Payload Test:

- For the full payload test we will combine all previously mentioned tests into one test run as an assembled unit (payload). This will be done over a span of at least an hour of continuous data logging, not only placing the payload in a dimly lit space, but an extremely lit space as well.
- The results from this test showed the payload was ready to be used in operation, after the code was edited with the help of Seyan. When initially tested the full payload test resulted in our Nuelog system logging all of the data it received, the camera system recorded video of the whole test, but our PTERODACTYL system did not properly save its data onto the micro SD card. This was fixed promptly, and a secondary test showed it to record the data correctly onto the SD card. In the end, the second complete test of the modules showed all parts of the payload to be functioning properly, recording the correct data which was accessible after the test was completed.

## 8.0 Expected Science Results

This flight may have a specific experiment, but at its root, we're trying to understand what changes occur to the environment as you travel up to near space, or roughly 100,000 feet above the earth's surface. Of all the modules contained within our payload, only a few let us quantify these changes. The modules that allow us to do this include a thermistor (temperature), pressure sensor (PTERODACTYL sensor and Neulog module), IR sensor, as well as the current and voltage Neulogs attached to our solar panels. These sensors will help us understand three values: Temperature, Pressure, and Solar Panel Efficiency. This section of the report will consist of our expected scientific results of how these values change.

Air pressure is the easiest of the three to understand, considering the theory behind it is quite straightforward. In its simplest form, the air pressure we feel at a given altitude is the weight of all the air particles located above us at that point. Essentially, the more atmosphere above, the greater the air pressure, and vice versa. As one travels higher in the atmosphere, there begins to be less and less atmosphere above. Plugging that into our understanding of air pressure, we can deduce that, as we travel through the atmosphere, air pressure will decrease.[2] Going one step further, the density of our atmosphere changes as well, with the highest density being near the ground, and the least dense occurring near space. This variation in density means that the change in air pressure won't be linear. It means that as you travel up, the air density will decrease slower and slower, since less and less air is present as you get closer to space. It will instead look like a curve, steeply decreasing at the beginning, and slowly decreasing as you continue to travel up. This can be seen in Figure 1, from Verhage's Near Space Article, showing a previous flight and its air pressure values vs. altitude.

Temperature is more difficult to predict, considering there are more factors to take into account as you travel through the atmosphere. There is one distinct relationship, though, that allows us to predict what is going to happen with temperature as altitude increases. This connection has to deal with the layers of the atmosphere. Now, these layers were not chosen by random but done so by looking at their properties, such as the composition of the air within them. Using this, we know that different molecules held within the air will absorb more or less heat, and therefore increase or decrease the temperature. In Figure 2, we can see this relationship on paper. As the figure shows the temperature decreases within the troposphere and mesosphere, whereas it increases significantly in the stratosphere and thermosphere. If we look at the composition of the stratosphere, we can see that this is where a majority of the ozone lies, and therefore it can trap a lot of the heat within this layer. As for the thermosphere, it is the first to be hit by the sun's radiation and therefore can reach extremely high temperatures. In the end, we get a varying scale of temperature vs. altitude, but for our flight specifically, we can predict that the temperature will decrease, to begin with, and then increase as it travels through the stratosphere.[2]

Last but not least, we have the efficiency of the solar panels. This is the main experiment of The Pyramid of Light and consists of two solar panels connected to two separate circuits, with each circuit connected to a voltage and current Neulog module. This will allow us to determine the output of the solar panels, or their efficiency, as they travel throughout the flight. Just like temperature, this is a very difficult thing to predict, considering the multiple variables that can affect solar panels. Factors such as light intensity, air density and pressure, and even gravitational pull, all contribute to how well the solar panel works. One factor, however, makes the most visible impact on solar panels, and that factor is temperature.[3] If we look back on the prediction for temperature, we know temperature varies greatly with altitude. Now, the real question is, how does temperature affect solar panels. For that, you need to know how a solar panel works. In its simplest form, a solar panel works by using photons from the sun to agitate the electrons surrounding the silicon atoms within the solar panel. This change in the movement of the electrons generates an electric current, which we then use to generate power from the panel.[4] Using this we can deduce that in colder temperatures the electrons surrounding silicon atoms are moving slower, and therefore when hit by a photon, will have a greater change in motion. This greater change in motion generates a bigger electric current and therefore greater power output. In the end, the colder a solar panel becomes, the more efficient it will be. This means that temperature and solar efficiency have an inversely proportional relationship; as one increases the other increases and vice versa. Using this, we can then predict that as temperature decreases during the beginning of the flight, the solar panels will become more efficient, and as the payload reaches the stratosphere it will begin to heat up and become less efficient till the balloon bursts.

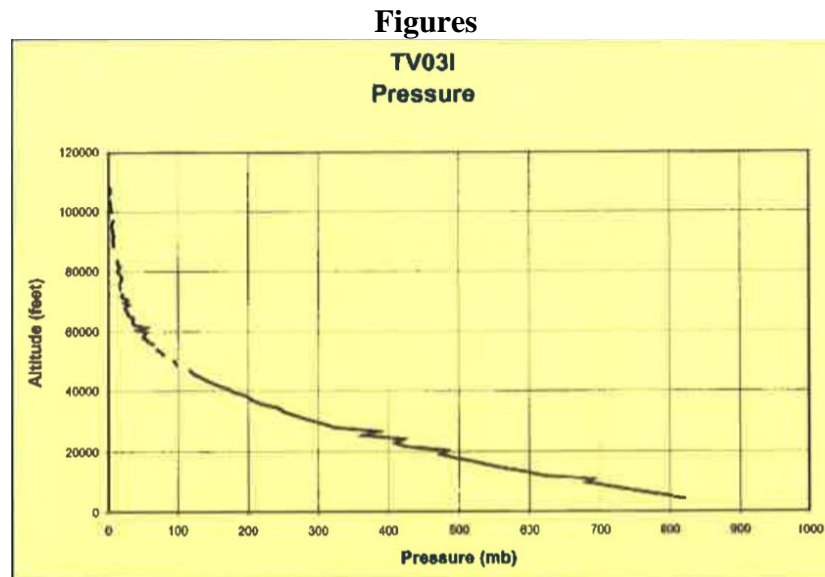

Figure 1 - This graph shows the Air Pressure (mB) vs. Altitude (Feet). Pressure decreases non-linearly toward zero (total vacuum). [2]

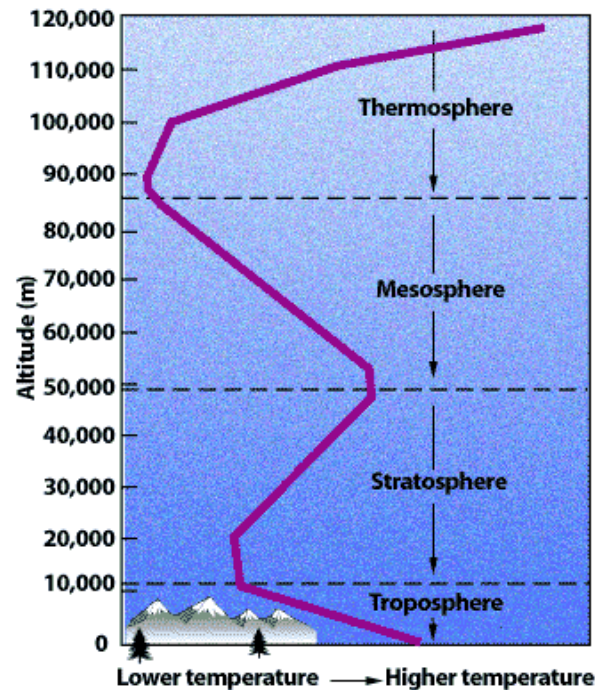

Figure 2 - This graphic shows the different layers of the atmosphere, as well as the changes in temperature. Most notably, the temperature doesn't change consistently, varying from decreasing to increasing at different altitudes. This is in part due to the composition of the atmosphere and the amount of energy from sunlight it absorbs at different altitudes. The ozone layer within the stratosphere causes one such spike in temperature, due to increased absorption of energy. [5]

## 9.0 Flight Day Narrative

Flight day began early on the morning of October 30th, 2021. We arrived at Akerman Hall before sunrise to get some last minute information about the launch as well as some time to fix some last minute errors with our payload. We had two main things to fix on our payload before we left for the launch site. First, we needed to code which of our PTERODACTYL sensors would talk to our units on the ground and give live data. Additionally, we consulted with some other students to decide whether or not to switch our lower Ohm resistors with higher Ohm resistors. Higher ohm resistors would have given us better current data for our current sensors to collect. However, we decided to continue with the resistors we were already using because it would have been complicated to attach new resistors and test them in the short amount of time before we needed to leave. The final thing we needed to accomplish before leaving for the launch site was to more firmly tie down our Neulogs, batteries, and cameras with zip-ties to insure their security during the flight. With these things finally accomplished, we left for our launch site in Janesville, MN. Once we arrived, we decided to launch our balloons from a grassy field area outside of a local school. We then needed to set up tarps on the ground where we would rig the payloads and balloons together. First we used the rigging on each of four payloads to attach them to one another. Our stack was rigged in the following order: balloon, parachute, tracker payload, team C payload, team D (our payload), and finally a camera payload. Rigging the payloads together was mainly a task of putting them together so that anything that needed to be oriented in a certain direction would be attached accordingly. Once the payloads were rigged, we began filling the balloon with helium. This process involved one person anchoring the balloon to their foot while several others kept the balloon off of the ground and as perpendicular to the ground as possible. While the balloons were being filled, the remainder of the group did the final steps of applying hand-warmers to the batteries in our payload, turning on the PTERODACTYL, Neulogs, and Light-Dow camera, and finally closing up the payloads with duct tape. After a half hour or so of this process, we were finally prepared to launch. We slowly allowed for the completely rigged stack to go from a horizontal position on the ground, to a vertical position now only held to the ground by professor Flaten. Before launch, Professor switched on the siren, and gave some last minute announcements and instructions for the following balloon tracking. Finally, Professor Flaten released the balloon which quickly ascended. Before long, the balloon was merely a small spot that could hardly be seen without thorough searching of the skies. At this point our group as well as team C went to a nearby subway for a much needed foot-long. All the while at the subway, every person in the group was intently looking at their phones, tracking the balloon. Once we finished lunch, we all piled back in the vans to catch up with the balloon. We stopped at several points along our route to stop and see if we could actually get a visual on our balloon. Unfortunately, we did not get a chance to see our balloon, but we did catch a glimpse of the research balloon. At a certain point, we got a phone call from team C letting us know that the balloon had landed near the town of Pine Island, MN and that they had seen it land somewhere in the middle of someone's land. We parked our van in the driveway of a very nice lady who was more than happy to allow us access to her land for our retrieval. It was not long after our arrival that we learned that our balloon had conveniently landed in a tree a mere few meters from a wide open, freshly harvested cornfield. In order to retrieve the balloon, we called Professor Flaten who had a truck with some extendable equipment for the very purpose of getting balloons out of trees. He arrived with a ladder, an extendable pole and some parachute cord that we used to remove the payload from the tree. We



did this by using the ladder to climb higher up with the extendable pole which we used to attach the parachute cord to the balloon stack. From this point it was a matter of strategically yanking on the chord to pull the balloon out of the tree. This took several attempts, but we finally landed the balloon on the ground. Our payload was relatively unscathed, however one solar panel had come partially loose and our external thermistor was whacked off just near the base of our pyramid. It was at this point that we powered off our PTERODACTYL, Neulogs, and camera to end our data collection. From this point forward, we packed up the payloads and headed back to campus to conclude our flight day.



To the left, our completed payload.

To the right, the inner workings of our payload including the PTERODACTYL, Neulogs, batteries, and camera (left); as well as our complete circuit (right)



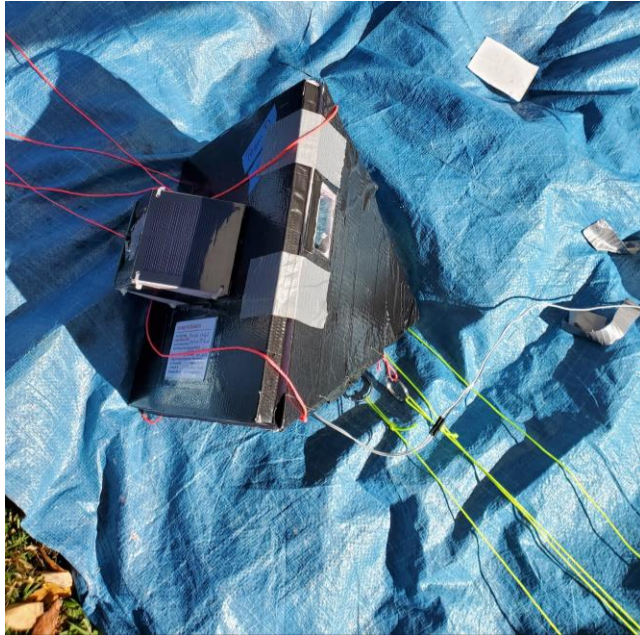

Our taped shut and fully rigged payload - ready for launch.



Balloon immediately after launch.

A few minutes after launch.

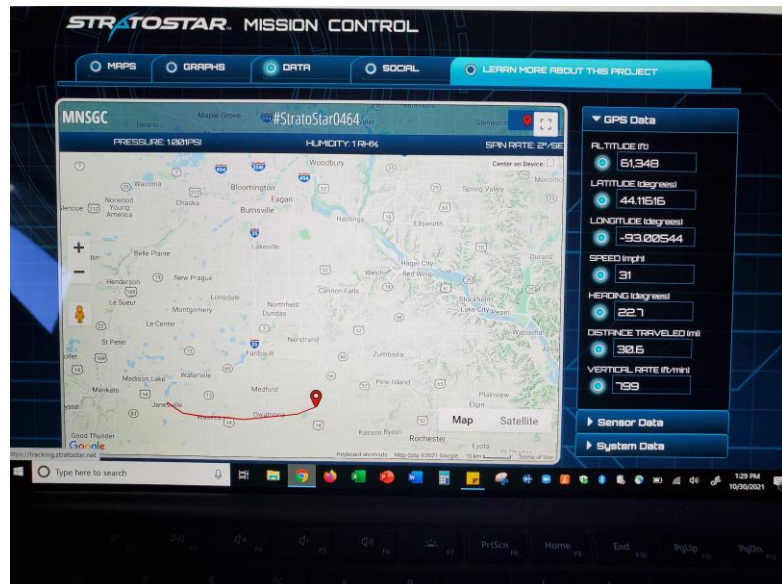

The Stratostar trajectory and GPS data.

## Retrieving the balloon



Here the external thermistor is seen detached from the extender wire - likely during the retrieval.

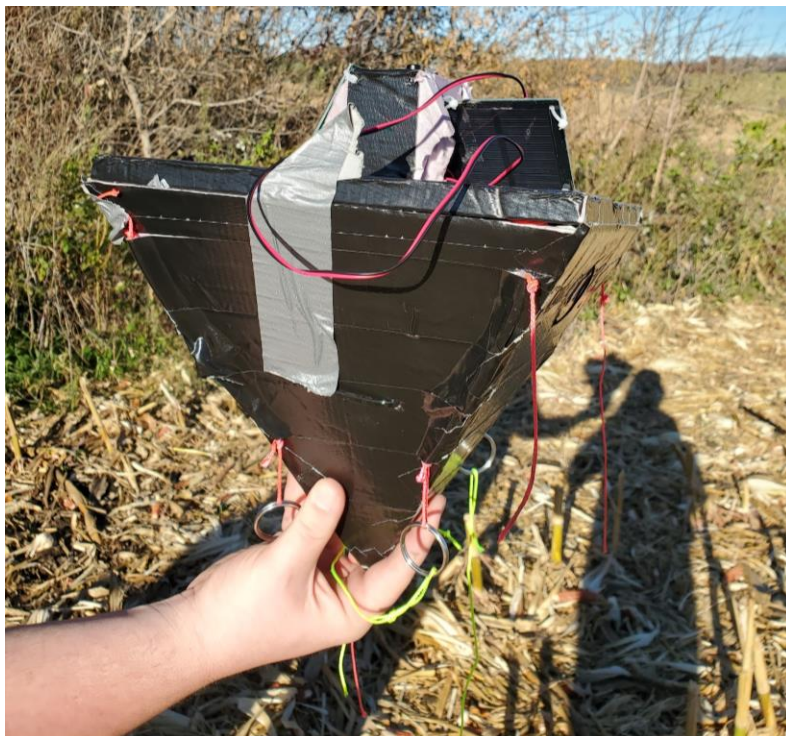

Post-flight payload. The detached solar panel can be seen in the top right. The solar panel was still wired, simply removed from the styrofoam.

## 10.0 Results and Analysis

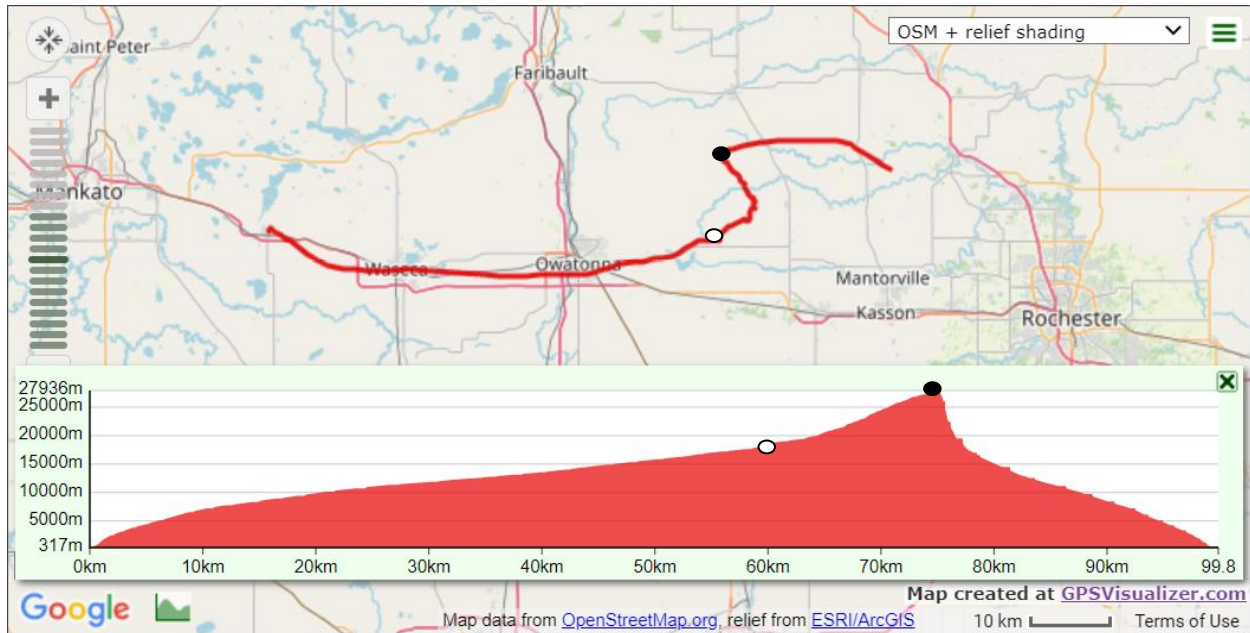

This is a map of the travel pattern of the balloon and the elevation is shown below made from PTERODACTYL latitude, longitude, and altitude. Notably the balloon travels East until 60km into the flight, at which it starts to ascend faster and travels North East, eventually moving North West. After bursting, the payloads fell East. This brings to question why the balloon ascended faster and switched direction after the 60km mark. If the data is correct, at 60km the balloon was at an altitude of 18500m. At this altitude the balloon would be in the stratosphere. The stratosphere starts at 12000m so this change in direction isn't just from the change in the part of the atmosphere. This change in direction could correlate to the absence or the presence of wind and the increase in ascent speed could be due to lower drag in the air. There is less air the higher into the atmosphere you go which does cause less of a buoyancy force, however, less drag as well. It could be that the less drag outdoes the lower buoyancy force.

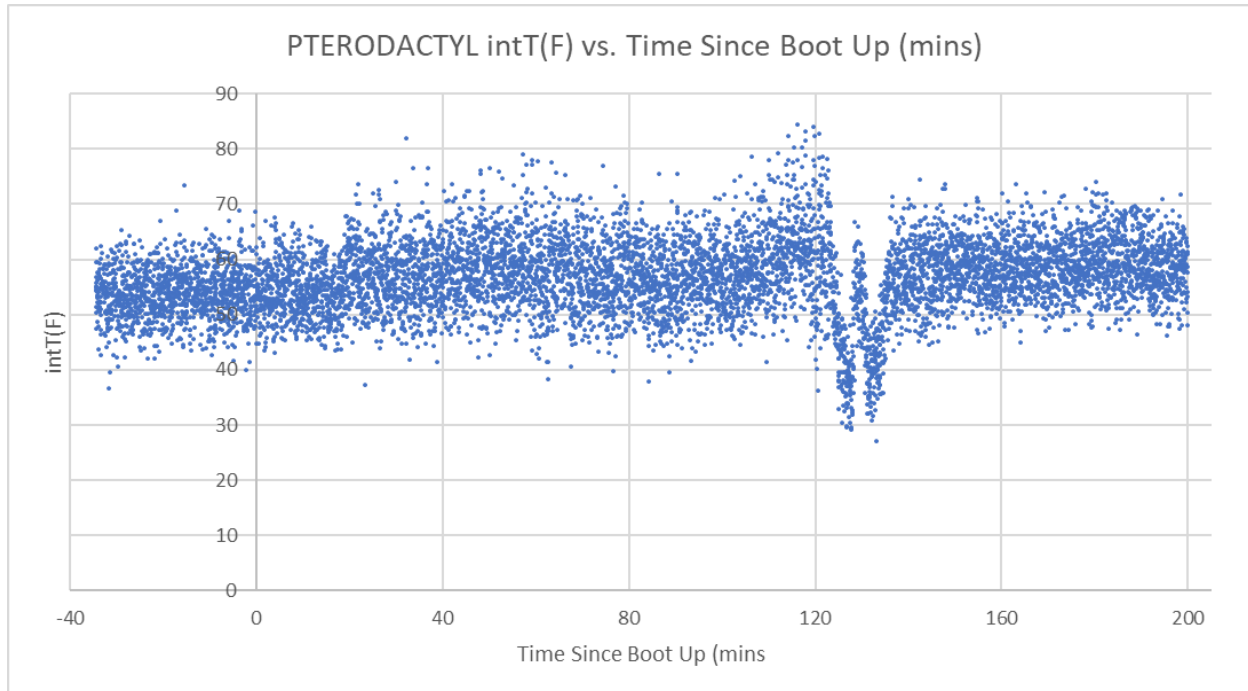

This graph shows the measured temperature inside the box during the flight. There is a large amount of noise in this graph which makes it hard to make any big assumptions. In general, the temp remains between 40 and 70 Fahrenheit which is good as it shows that the insulation and heat packs worked. Just after 120 mins after being booted up is when the payload landed in a tree. The spike present at this time may be due to the payload being damaged and the internal temperature probe being open to the outdoor temperature which was roughly 40-50 Fahrenheit on the day of launch.

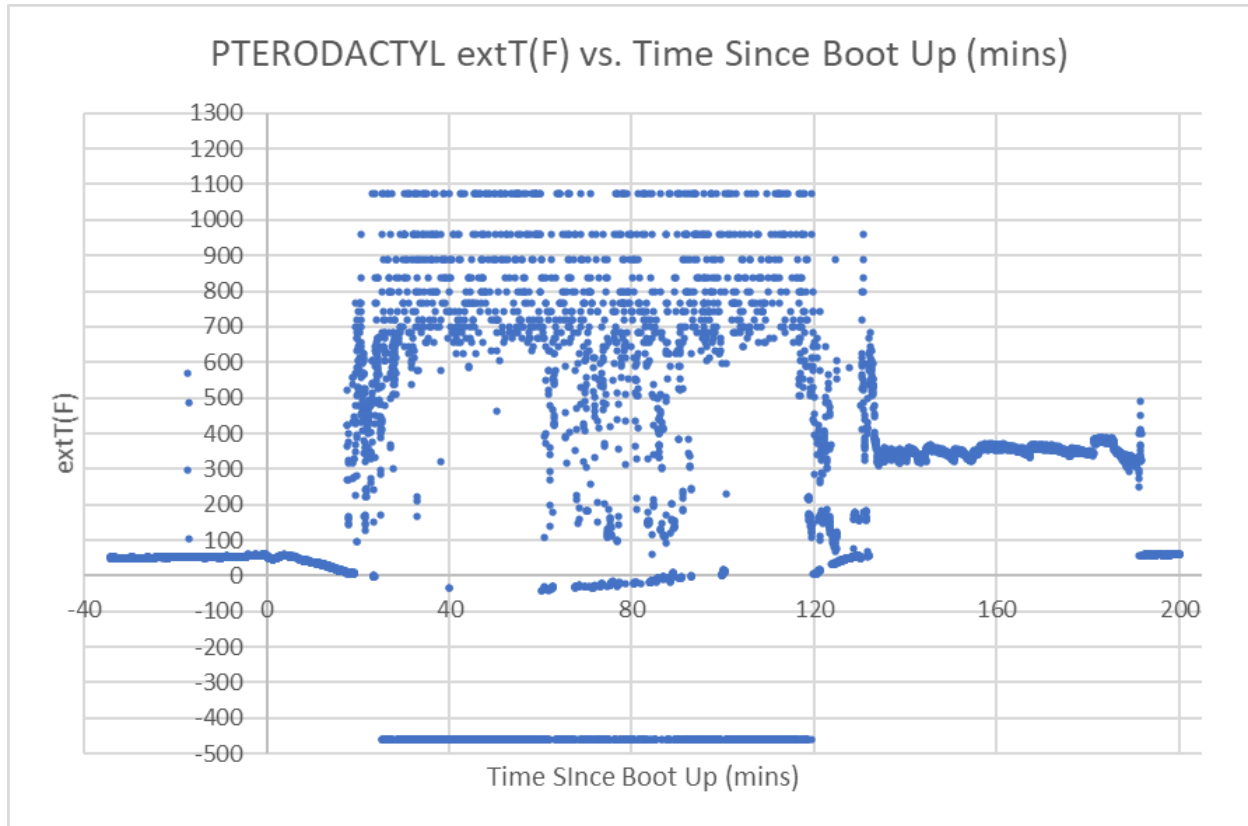

This graph is of the external temperature and time since boot up. This graph is clearly incorrect although it does have moments of clarity. The wildly incorrect parts could be due to extreme temperatures that caused the probe to stop working. Another possibility could be that the box was shaken and swung enough to partially disconnect the wire for the probe. This is less likely as sections of clarity come and go and this kind of problem would result in the probe stop functioning at all.

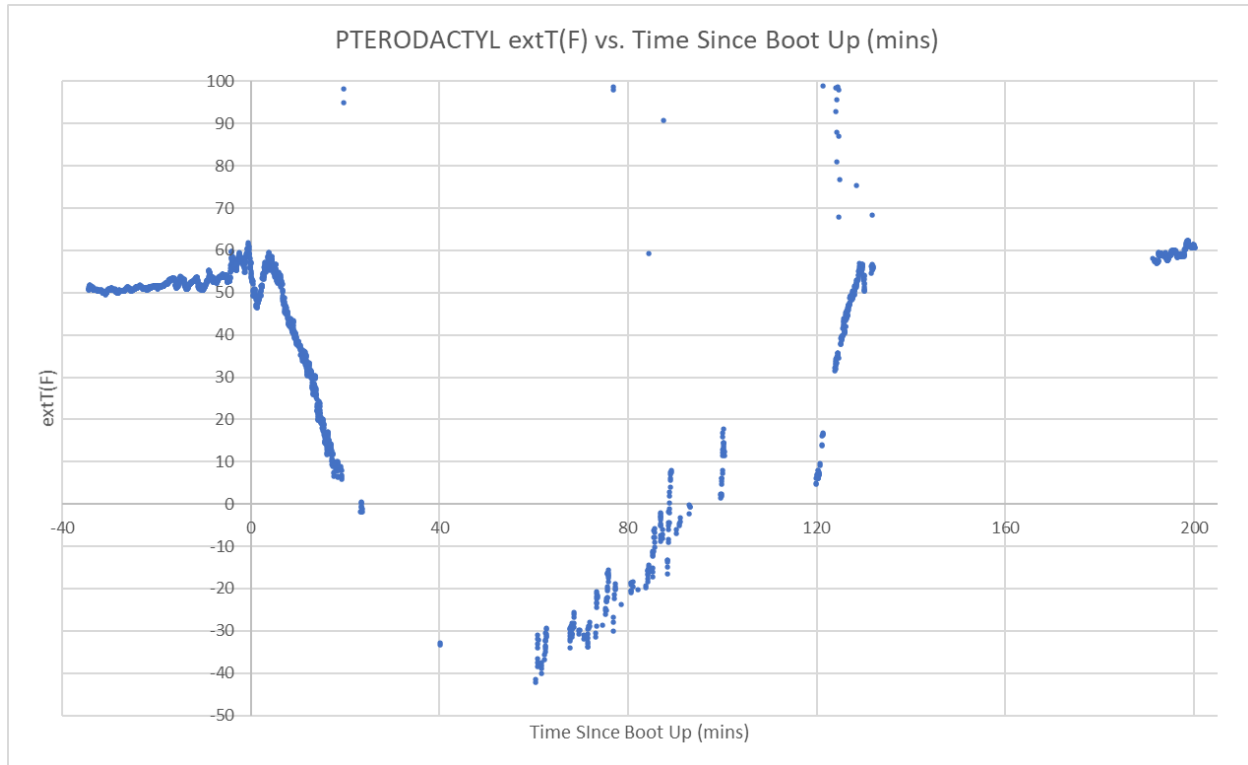

This graph is the parts of the external temperature graph that have some clarity. The probe was working at the start of the launch and we can see that the temperature lowers as the balloon ascends. At 20 mins into the flight the probe stops working and never comes back to full functioning. Looking at the video the probe does not violently shake or seem to wildly move, however, you do hear some odd noises, sounding almost like deep moans. These noises are most likely made by strong wind which could have done something to the probe.

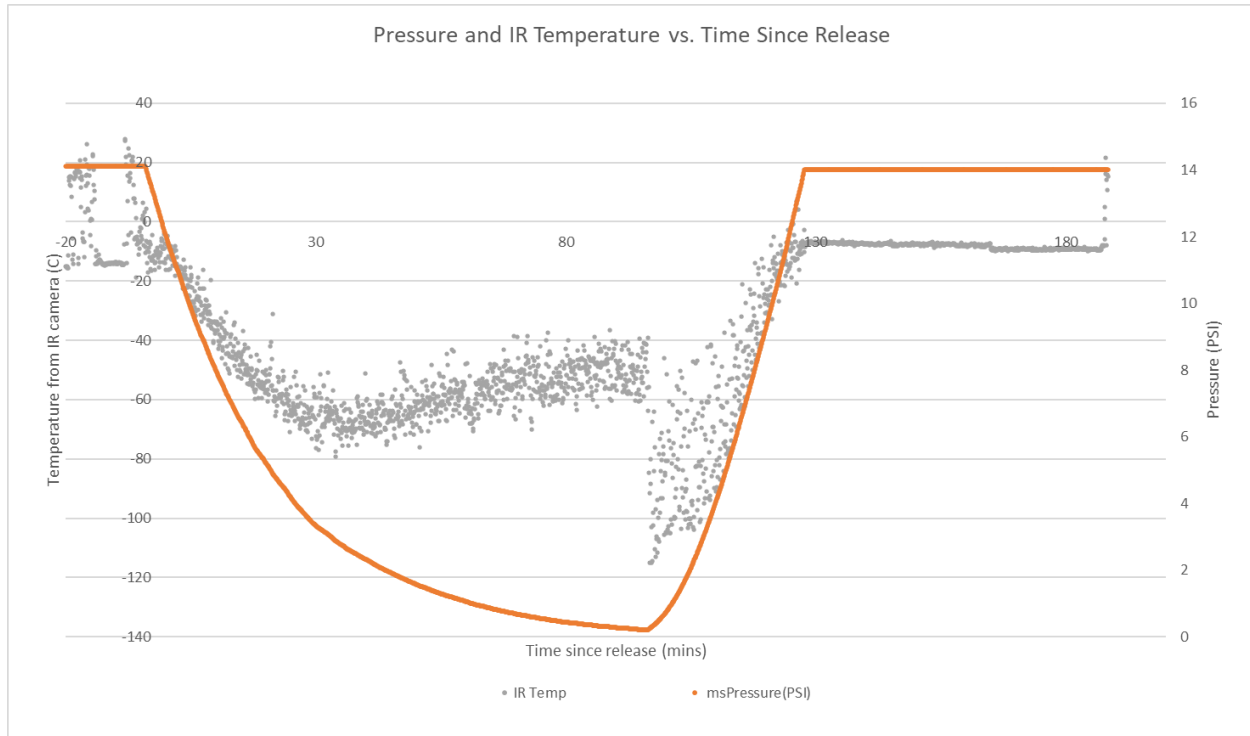

This graph shows the temperature data collected by the IR camera pointed at the other teams payload and the pressure. Pressure is used instead of altitude as the altitude could only be estimated by this PTERODACTYL. We can use the pressure to get an idea of what altitude the payload is at. We can see that during the ascent the temperature data follows the general known relation between altitude and temperature. The noise before the launch is most likely due to the camera focusing on random objects and/or the sky where there is nothing to look at. There is also a large amount of noise when the balloon bursts. I again think that this is due to the camera not focusing on a subject. We can see from the video that the payloads whip around which would cause the assumed situation. When the balloon lands the IR camera rests at roughly -10 Celsius. This is clearly incorrect and it may come from the camera pointing towards the sky or horizon and thus was not focused on anything to get proper data from. Sadly the camera did not function at this point of the flight and so we can't see how the balloon was orientated once it landed.



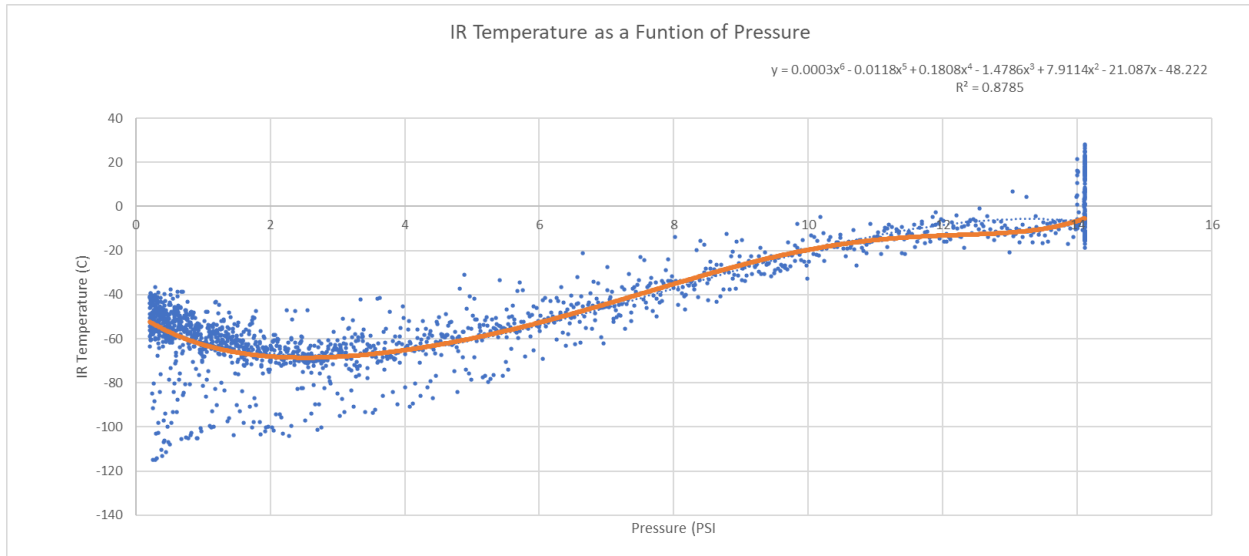

This graph shows the relationship between the temperature of the other payload from the IR camera and the pressure from the PTERODACTYL. This isn't a very important relationship but it is interesting that it can be made. This relationship can be drawn most likely because in general the temperature follows a pattern as altitude goes up and pressure goes down as altitude goes up. This comes together in this graph to show how temperature goes down then back up a little as the pressure decreases. This graph is really only useful to see this relation as the altitude could only be estimated by this PTERODACTYL.

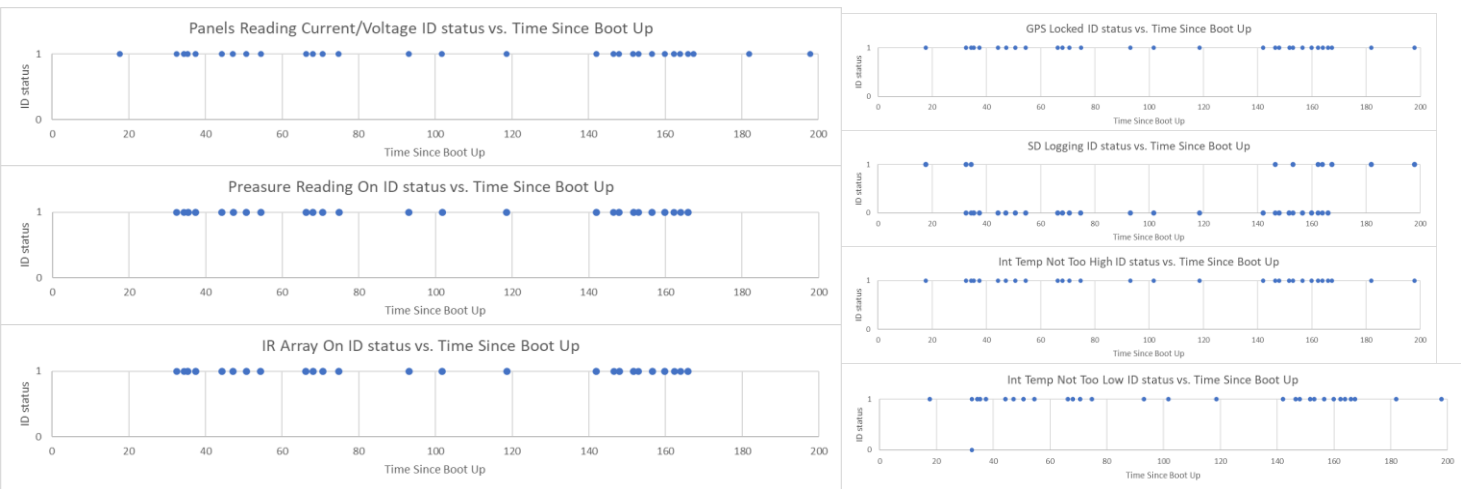

These are the graphs for all of the status IDs. Truthfully it is hard to make any claims from the ID line. We never got the full ID line that we tried to get which was 01111111. At times we would get something close, however, we would get lines of five or six numbers instead of eight. This also made it hard to parse as it was unsure which IDs came through and which did not. The only ID that did change from a 1 to a 0 was the SD logging ID. This could be correct as this SD did not record at locational data and the data was cut up into many excel files.

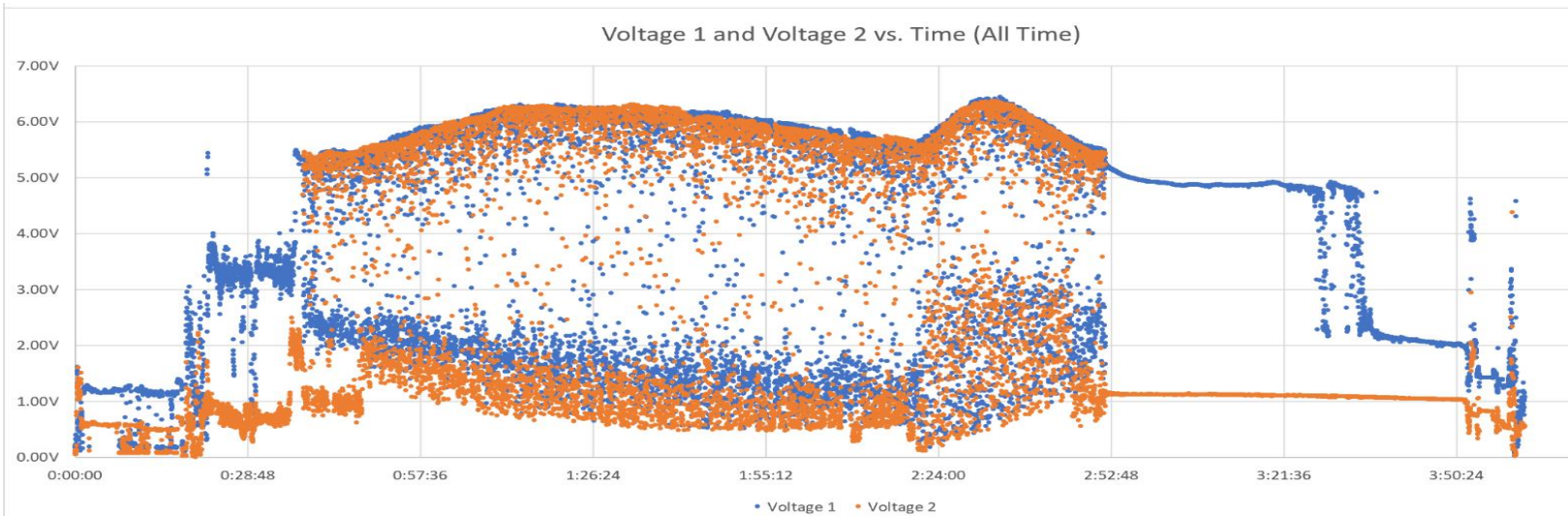

This graph shows both voltage values we collected with respect to time. Each voltage sensor was connected to a solar panel. The solar panels were positioned on the top of our payload on opposite sides from one another so that one of them would always be likely to have full sunlight. This means that while one sensor was getting its maximum value, the other was getting its minimum value. This is depicted in the graph by two trends in the data. Particularly from timestamp 0:28:48 until timestamp 2:52:48, we can see that voltages have a heavy low voltage trend and a heavy high voltage trend. The highest voltage points represent when each voltage sensor was aimed directly at the sun therefore reaching maximum solar efficiency. The outlying points in the middle represent three different things relative to the position of the solar panels. First, the points closest to the middle represent when the payload was hanging straight down and rotated so that each voltage sensor was receiving equal amounts of solar energy. The outlying points with higher voltage values than the average for each sensor represent what I think is when the payload was swinging so that both solar panels were pointed at an angle towards the sun therefore receiving more solar energy.

These two

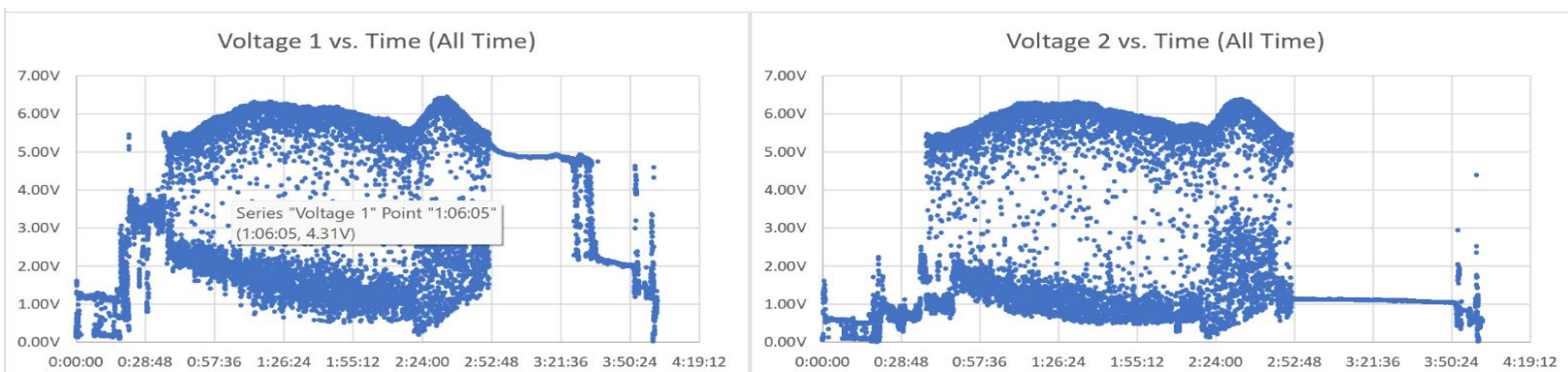

graphs are the same as the previous except that each voltage sensor is plotted separately. The trends can be seen more clearly.

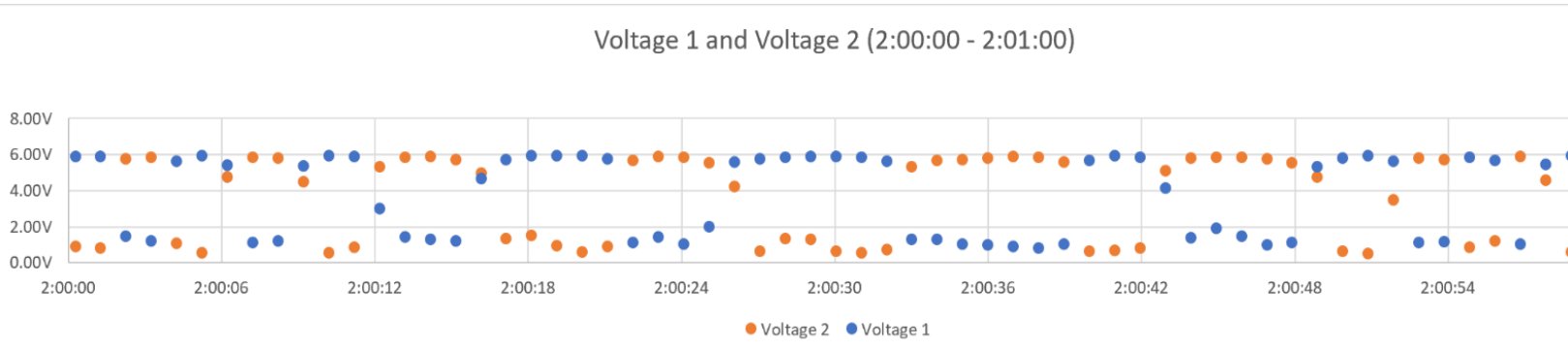

This graph represents a close up view of the same data as the previous graph. It demonstrates both voltage sensors with respect to time over a one minute interval. This is mainly to better represent my above explanations of the data. Here we can clearly see that as every second that passes we have one voltage value from each sensor. One of the values is always higher and one of the values is always lower. In addition to that, from point to point, when one value increases, the other decreases. This is because one sensor is always getting more sunlight than the other, as the payload rotates and swings, we can see the change.

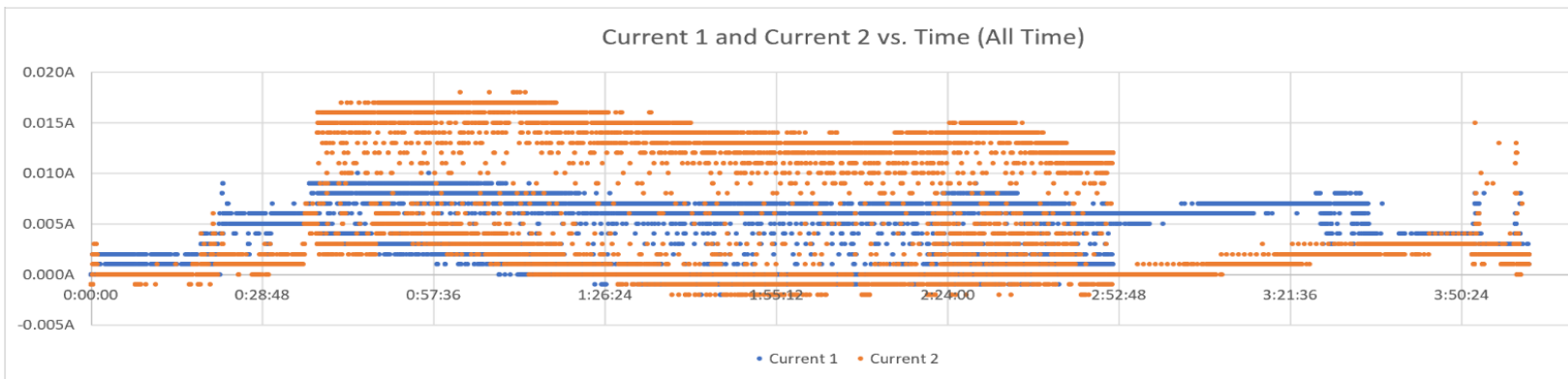

This graph represents both of our current sensor values with respect to time. Similar to our voltage sensors, each current sensor was hooked up to a solar panel. Current sensor one and voltage sensor one were connected to the same solar panel, and current sensor two and voltage sensor two were connected to the same solar panel. Here we can see a similar trend to voltage. Each current value has high and low trending values, and those trends follow very similar trend lines. It is therefore reasonable to assume that these trends are created with similar explanations as the voltage trends.

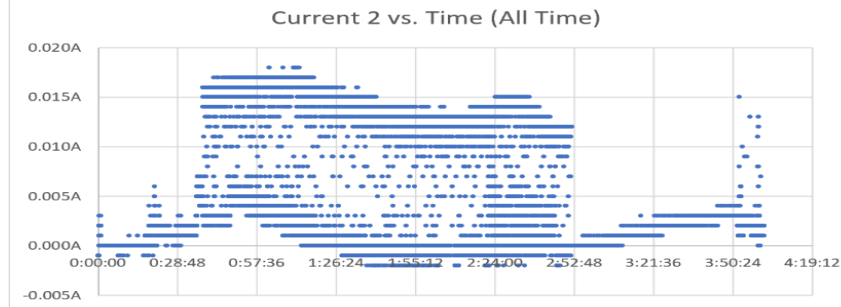
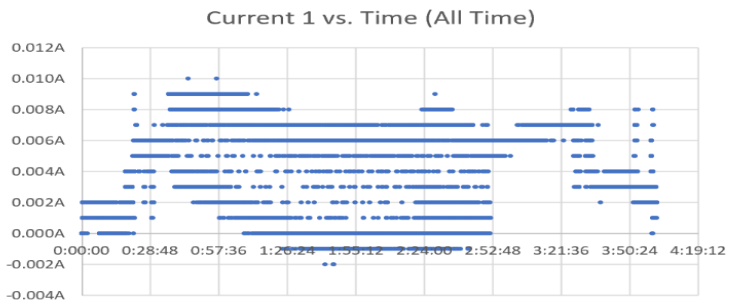

These two graphs are the same as the previous except that each current sensor is plotted separately. The trends can be seen more clearly.

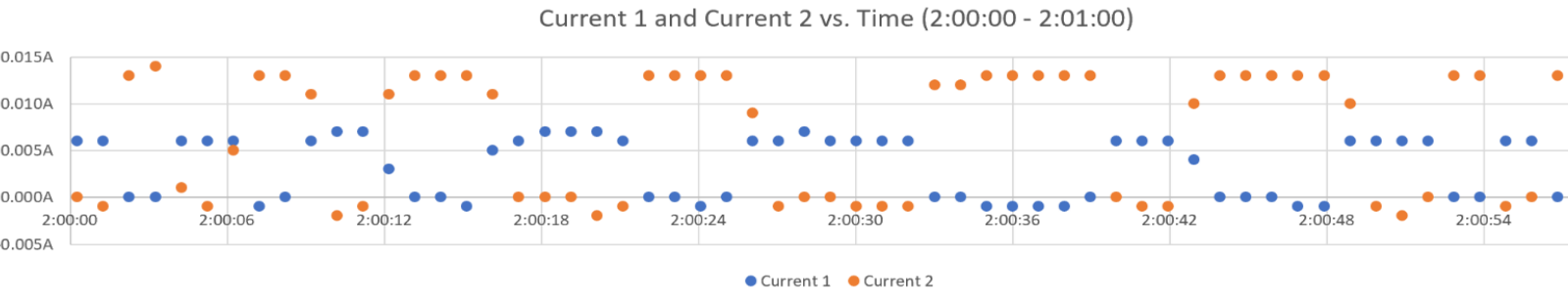

This graph displays both current values with respect to time over the same one-minute interval as the voltage graph. Like voltage we can see that each current value is seemingly opposite from point to point as the other sensor. Discrepancies in this are I think mainly due to swaying with effects as described before.

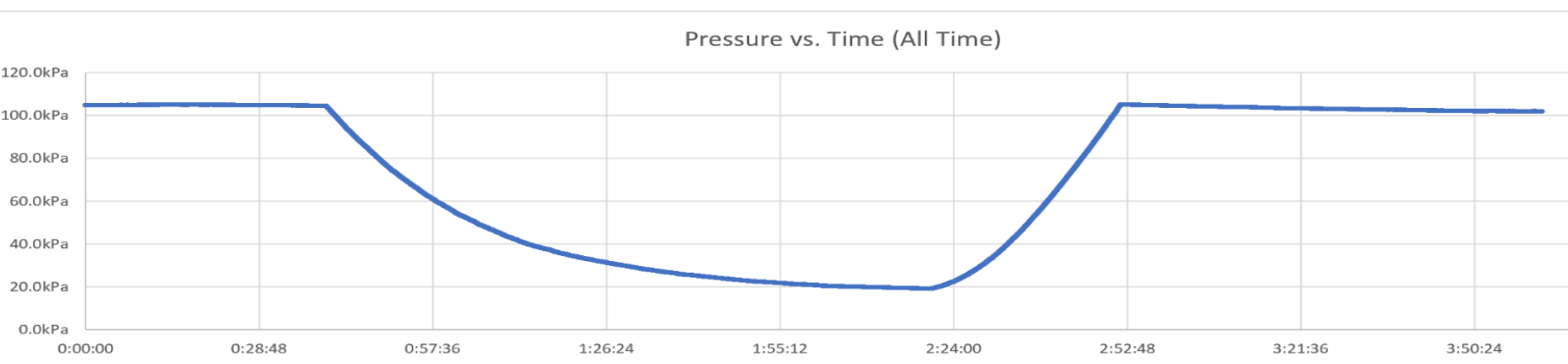

This graph represents our pressure data with respect to time. It is very easy to see that the data collected for pressure was incredibly accurate since the trend line is so smooth. Once the balloon launched (the point on the graph where the data starts to significantly change) the pressure began

dropping rapidly and started to slow its decrease near the end of the ascent. At the point where the pressure started increasing again, is the point where the balloon burst. It is at this point where the data increases pretty consistently until the point where the pressure flatlines which is when the balloon landed. Interestingly, once the balloon lands (approximately time 2:52:48) the pressure begins decreasing again at a very slow rate. I hypothesize that this is due to the change in temperature with the changing time of day. It took over an hour before the payload was retrieved and the data stopped collecting which is plenty of time for the temperature to drop enough to noticeably change the pressure. It is also important to note that the Neulog Pressure sensor was not equipped to deal with the higher altitudes of the flight.

Voltage 1 vs. Pressure (All Time)

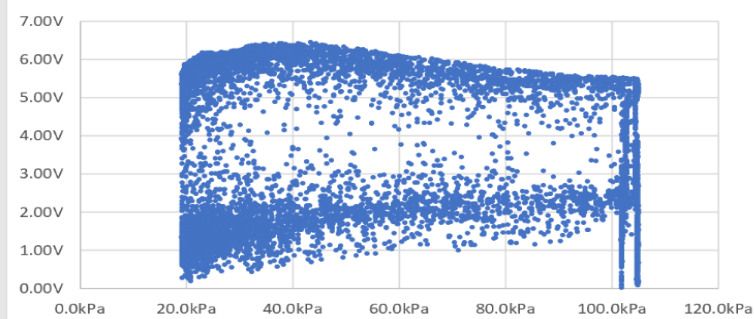

Voltage 2 vs. Pressure (All Time)

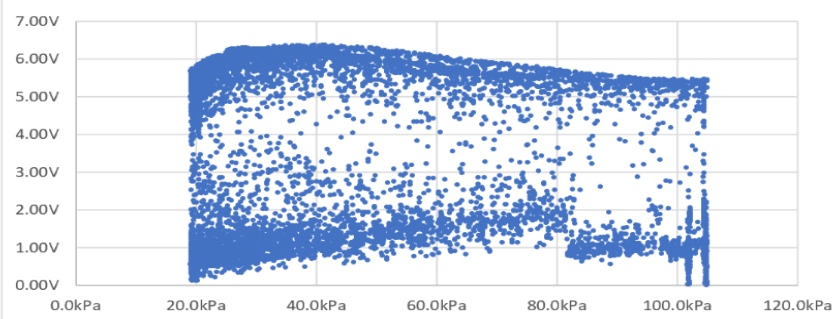

These graphs display each voltage value with respect to increase in pressure. Increase in pressure correlates with decrease in altitude. What we can see in each of these data is that the minimum voltage value for each sensor seems to gradually increase while the maximum voltage values seem to increase briefly and then decrease semi-consistently until the end of the flight. This means that as altitude decreases, the maximum and minimum values come closer together giving a more consistent and efficient use of the sun's solar energy.

### IMU Sensor Graphs: Magnetometer/Accelerometer/Gyroscope vs. Time Since Launch:

The following 9 graphs were created from data collected from the 9-axis IMU sensor attached to the PTERODACTYL. This consists of magnetometer, accelerometer, and gyroscope data from three axes each. Each graph gives insight into the overall motion of the payload, as well as helps us pinpoint major events during the payload's flight.

**Magnetometer:** The first three graphs consist of the 3 axes of the magnetometer, which measures the magnetic field of the earth. A positive value indicates that the axis is pointed in the same direction that the magnetic field points. At the same time, a negative value indicates the axis is pointed in the opposite direction that the magnetic field points.

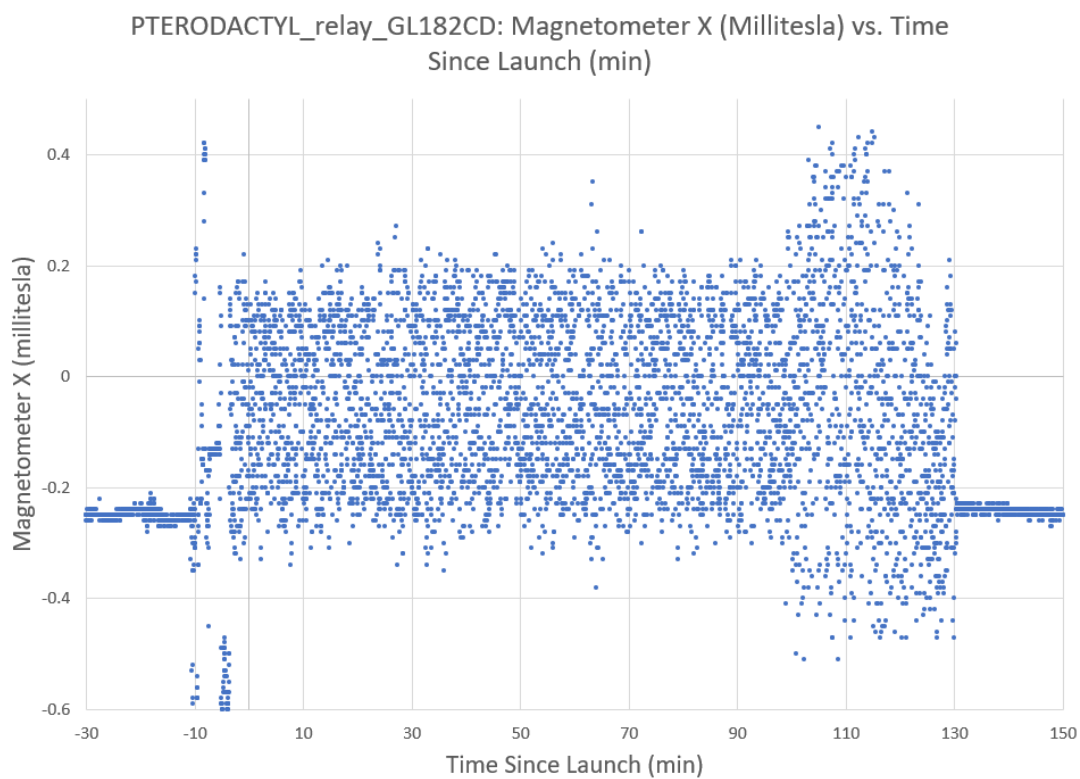

The graph above shows the x-axis of the magnetometer versus time. Right off the bat, you can see 4 major parts of the graph. The first and last bits show a relatively constant value of around -0.25 millitesla. These times show before and after the flight of the payload, resting on the ground (or 60 feet up in a tree). Since it's negative, the x-axis at this time must have been pointing opposite the magnetic field of the earth. Once the flight begins, the value changes constantly throughout the flight, becoming especially sporadic at around 100 minutes. This marks when the balloon burst and sent the payloads spiraling towards the ground. Overall, the values during the flight averaged around zero, meaning that the box was spinning, changing the direction the x-axis pointed constantly throughout the flight.

The graph above shows the y-axis of the magnetometer versus time. Right off the bat, 4 differing areas can be seen. The beginning and end show almost constant values, with pre-flight being

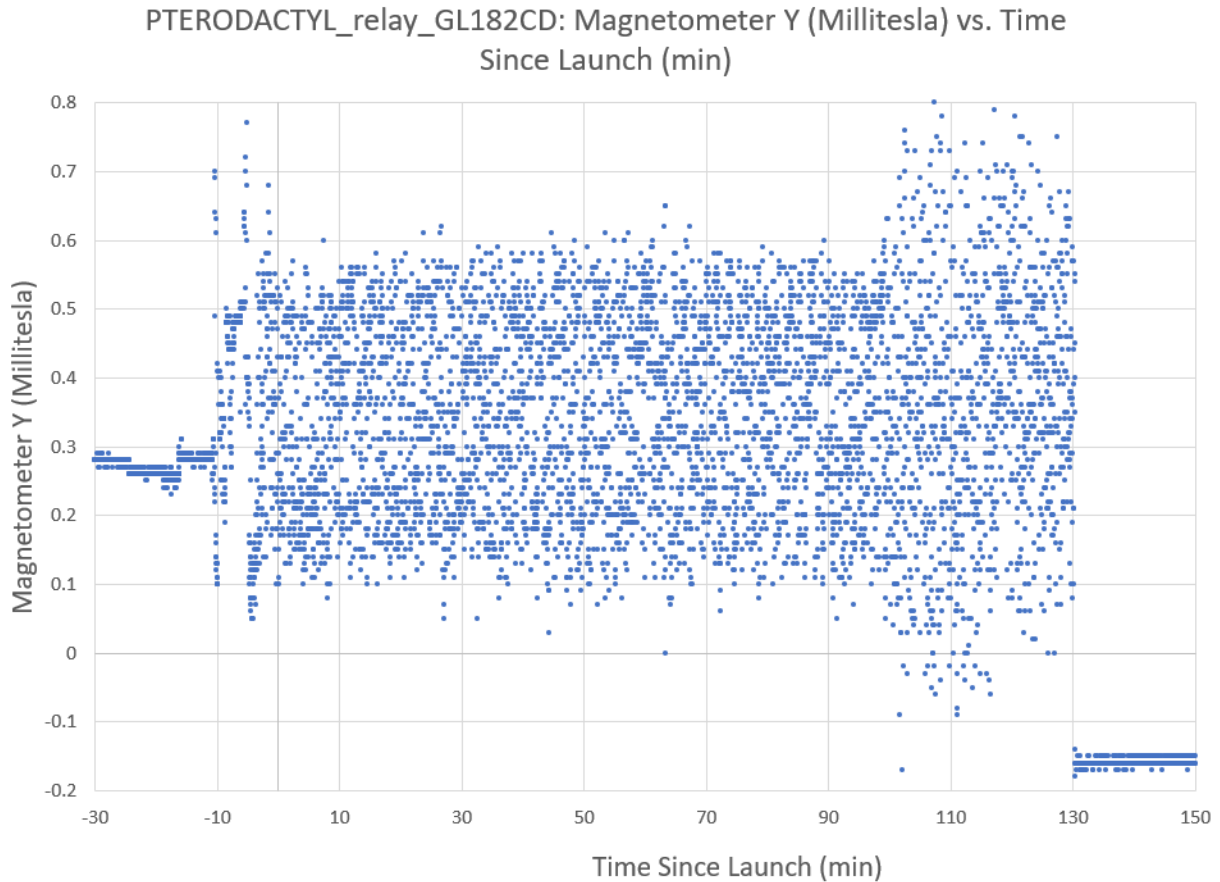

positive, and post-landing being negative. This means that the y-axis was in line with the magnetic field before the flight, and opposite after it landed. During the flight, we see a similar graph to the x-axis, but the values average around a positive 0.3 millitesla. This indicates that throughout the flight the y axis must have been pointed towards the direction of the magnetic field of the earth. Right around 100 minutes, just like the x-axis, the values become sporadic. This again shows where the balloon burst and the payloads began to fall. The x and y axes must have been on the same plane compared to the magnetic field, because of how close the graphs look, even if the y-axis had a positive average value.

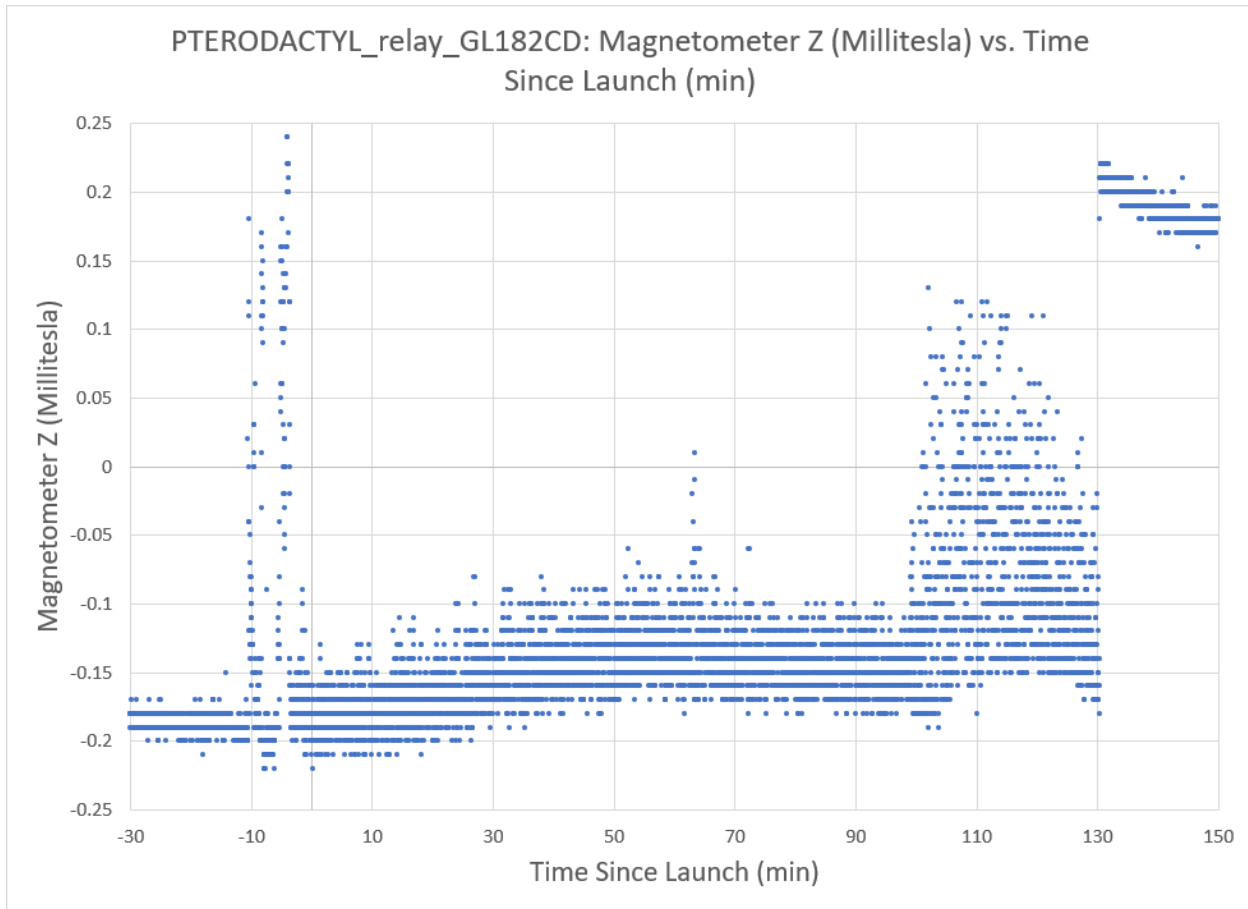

Above is the graph of the z-axis on the magnetometer versus time. Immediately, this graph looks much different than the other two axes. This can be explained by the direction each axis faces. The x and y axes were in the same plane, considering the very similar graph style, especially the variation in values that indicated rotation of the payload. The z-axis, however, is pointed straight up. That is why the value received from the z-axis doesn't fluctuate, considering the rotation of the payload does not affect the payload vertically, only horizontally. Since the value was almost always negative, it must have been pointing opposite the direction of the earth's magnetic field. Again, right around 100 minutes, the values jump around, indicating that the balloon has burst. When it landed, however, the payload flipped upside down, and the z-axis pointed in the same direction as the earth's magnetic field, which explains the constant positive value after 130 minutes.



Accelerometer: The second set of three graphs consist of the IMU's 3 axis accelerometer. Accelerometers measure the forces acting on them, such as gravity. This specific value allows us to determine the orientation of a payload concerning the gravity acting on it. Whatever axis reads a value close to one g, or 9.8 meters/sec<sup>2</sup>, that axis must be parallel to the direction of gravity. The graph above is the data from the x-axis of the accelerometer versus time. Four major

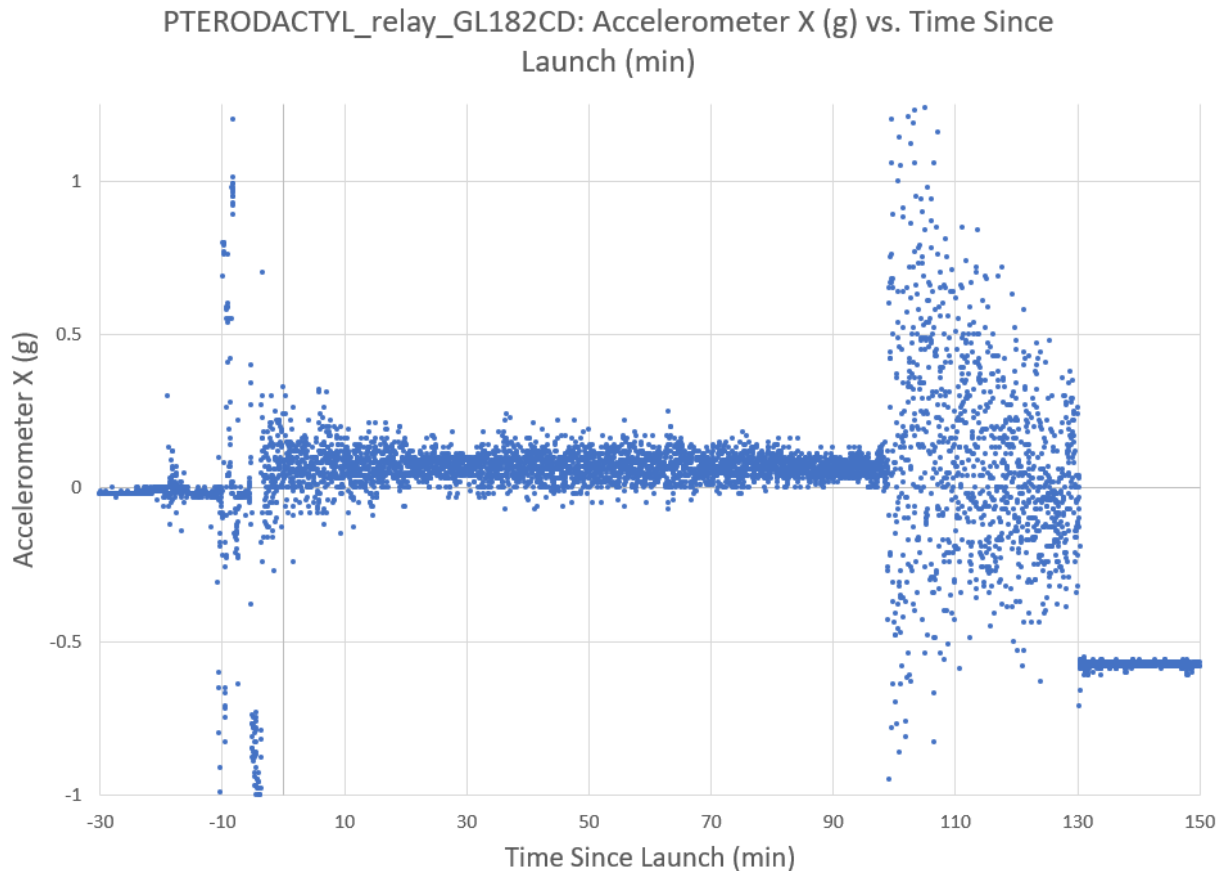

changes can be seen during the length of the flight. Before the payload was launched and after it landed, the x-axis measured a constant value, which should be true since the payload was stationary at those points. Before the flight, the value was roughly 0, whereas after landing it read roughly -0.5 g's. This is because the payload is oriented differently at each point. Before it must not have been in line with gravity, reading an acceleration of zero. After it landed though, the x-axis must have been pointed slightly opposite the direction of gravity, resulting in a negative value. During the flight, the data averages at around .1 g's, which means the x-axis was almost perfectly perpendicular to gravity during the entire flight. At around 100 minutes, the values become sporadic, indicating that the balloon burst.

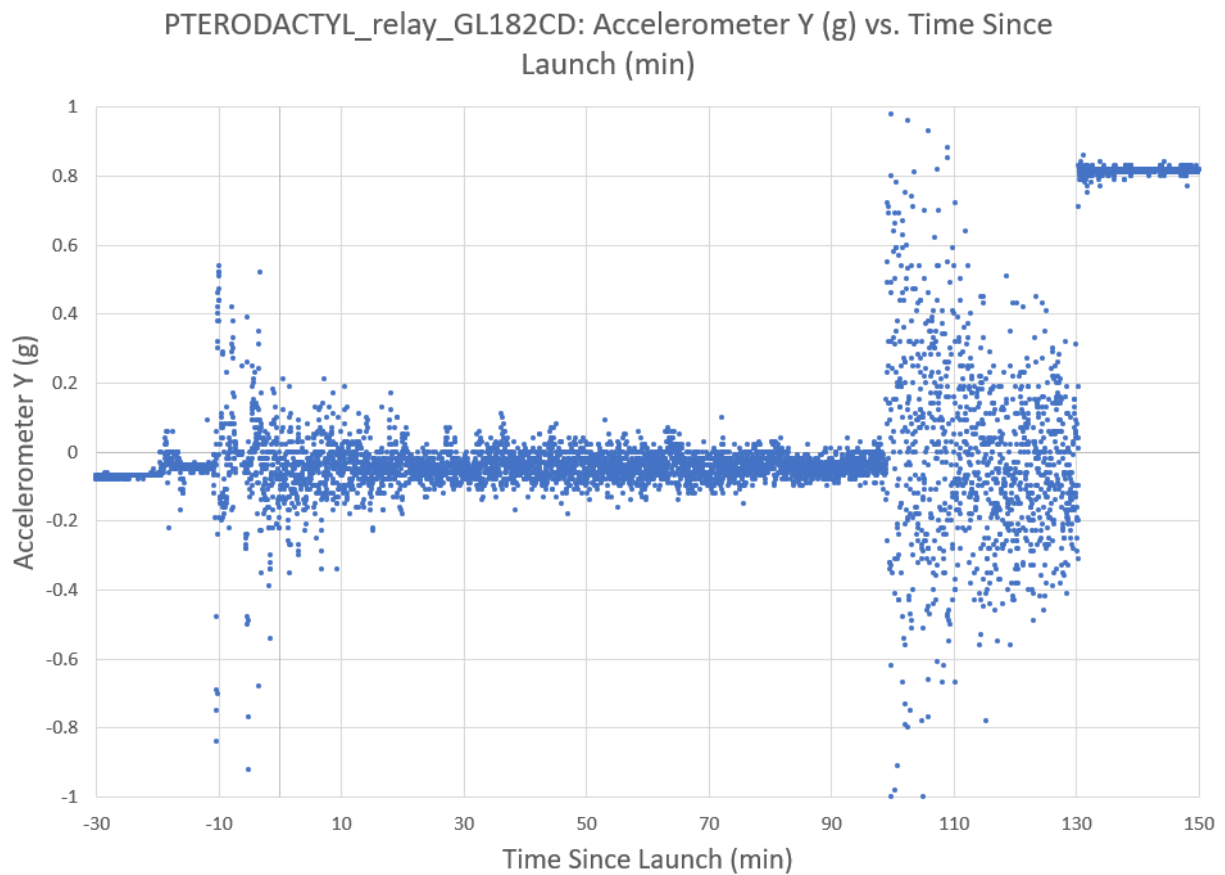

Above is the graph of the y axis of the accelerometer vs time. This graph is almost identical to the graph of the x-axis, except that the value is slightly negative. This is because the plane that both the x and y axes fall on is slightly tilted, meaning one axis got a slightly positive acceleration during the flight, while the other got a slight negative acceleration. Other than that fact, it is almost a duplicate of the x-axis, other than the acceleration after it landed. In this case, the value is almost one g. That means the orientation of the box after it landed must have flipped the y axis to face the direction of gravity, resulting in that one g value.

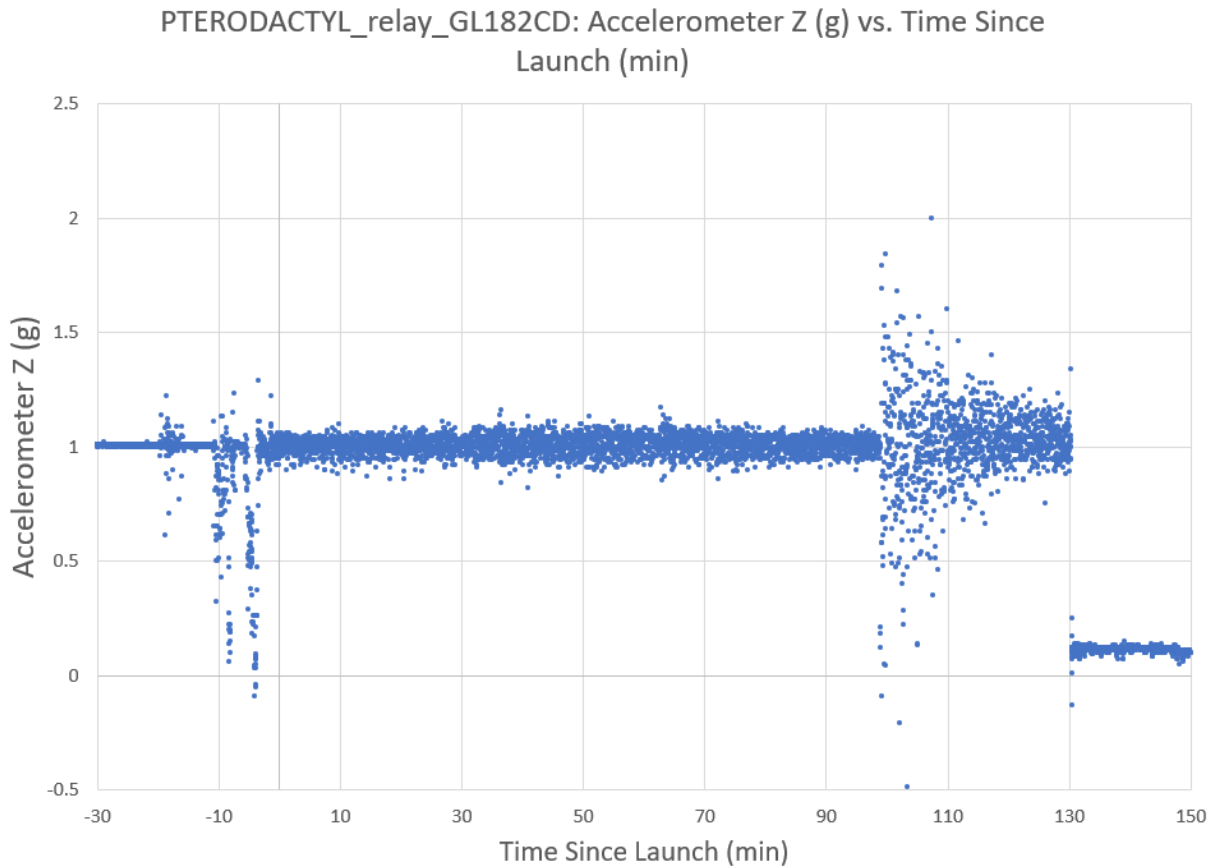

Above is the graph of the z-axis of the accelerometer vs. time. This graph is a little different than the other two. Other than the similar point where the values become sporadic, which indicates the balloon bursting, one very big difference can be seen. Over almost the entirety of the flight, including before we launched the payload, the z-axis got a reading of 1 g, or  $9.8 \text{ meters/sec}^2$ . This makes sense since the z-axis was pointed vertically, right in line with the direction gravity was acting on the payload. Gravity is always acting on the payload, even at 100,000 feet above sea level. When the payload landed, we can see that the z-axis must have been flipped over onto its side considering the reading becomes close to zero.

Gyroscope: The last set of IMU graphs show the gyroscope, which measures angular velocity in 3 axes or the speed and direction of rotation that an axis has. This is especially useful to determine when our payload was rotating and at what speed.

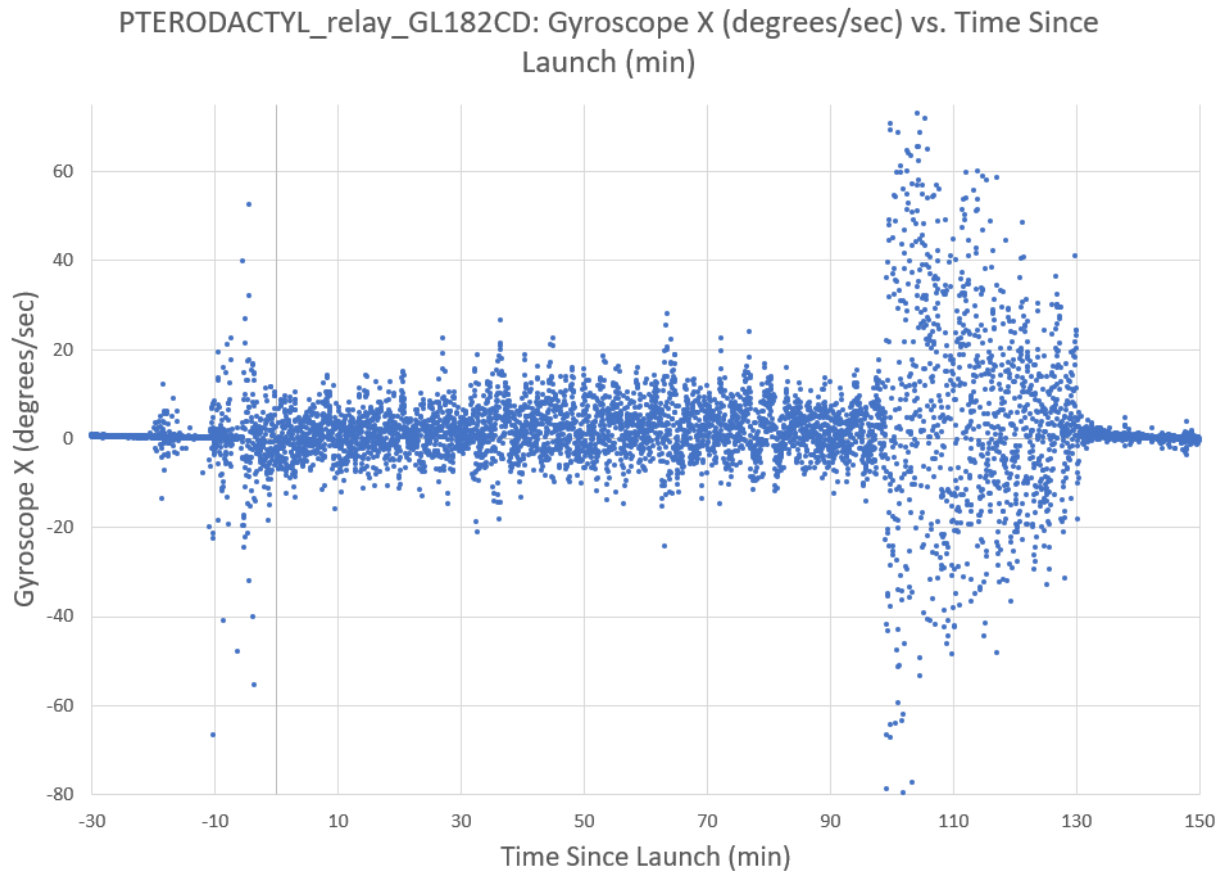

The graph above shows the gyroscope's x-axis angular velocity vs. time. Before and after the flight we can see a clear zero angular velocity, which is true since the box is stationary before launch and after landing. Just like the other graphs from the IMU, a clear divide is seen during the flight around 100 minutes. This is where the balloon burst and the payload began to descend, fluctuating the angular velocity greatly. During the ascension, though, the angular velocity changed between positive and negative 10 degrees per second. This makes a lot of sense when considering the direction the x-axis faced. The x-axis was parallel to the ground, so the gyroscope was measuring the sway of the payload. This is very similar to the y axis since it's on the same plane, parallel to the ground.

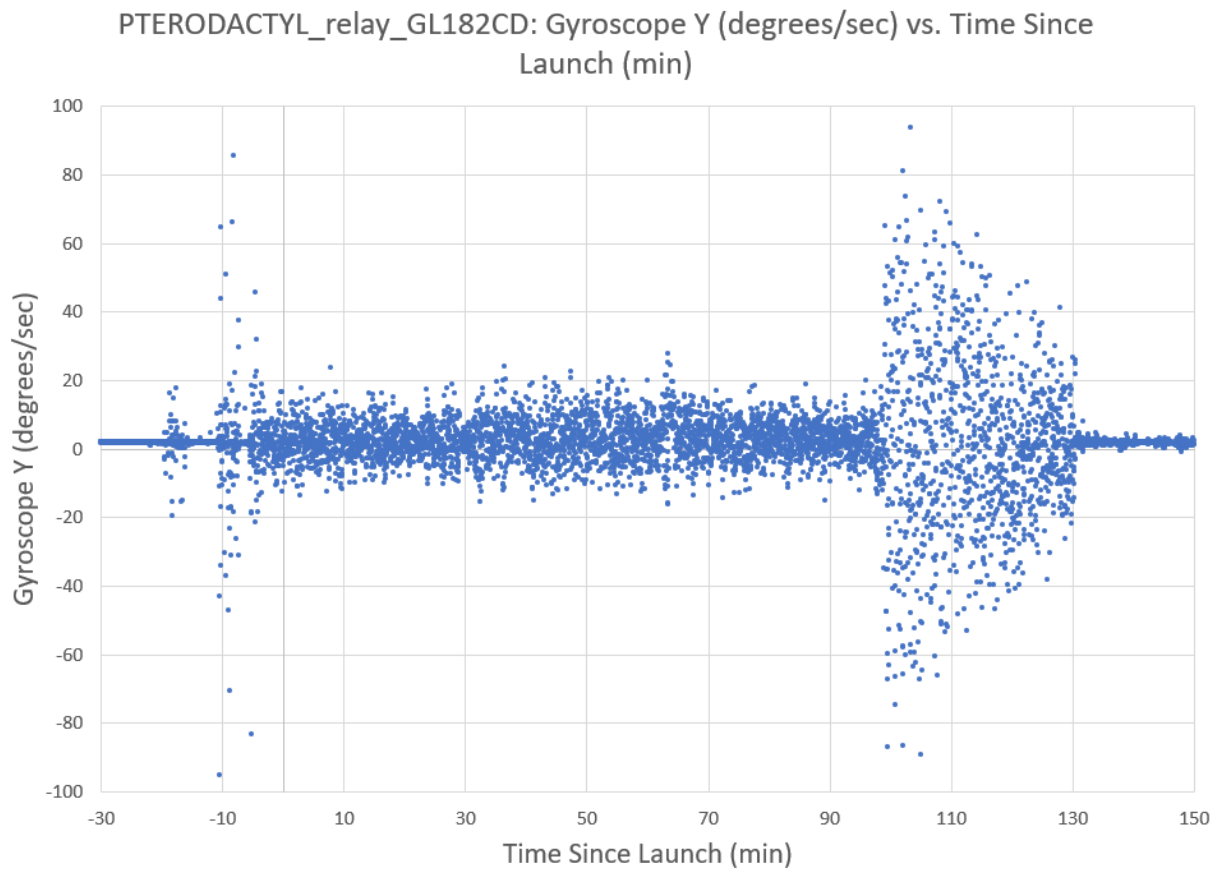

Above is the graph showing the gyroscope's angular velocity in the y-axis vs. time. This graph is almost identical to the gyroscope's x-axis. The point at which the balloon bursts, the angular velocity before and after the flight being zero, and even the change of positive to negative 10 degrees per second during the flight. Each part of the graph is almost a carbon copy of the x-axis. This is because both axes land on the same plane, parallel to the ground. This means that both the x and y axes only measure the sway of the balloon, which is very fast and minuscule, justifying the two graphs being almost identical.

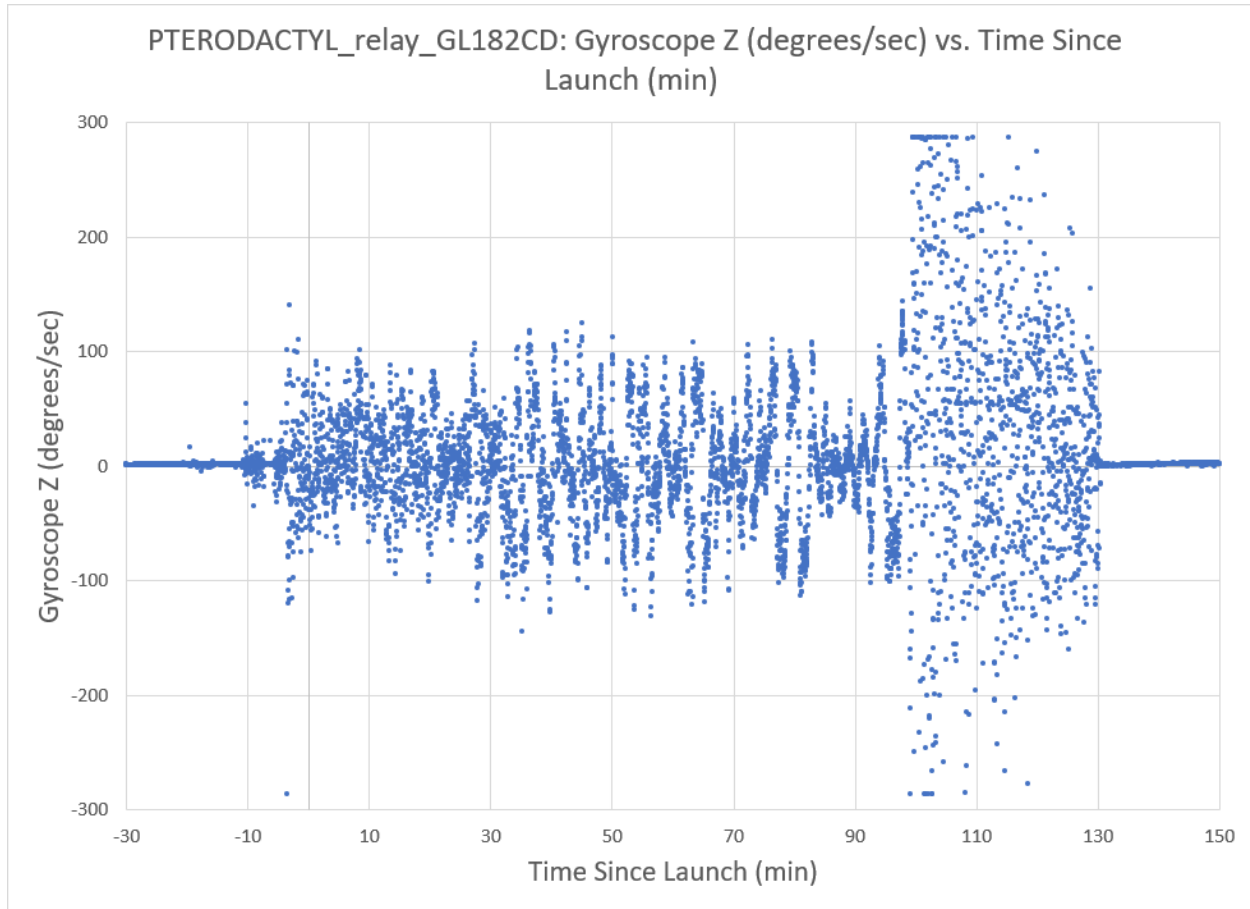

The graph above shows the gyroscope's z-axis angular velocity vs. time. For the most part, the z-axis is quite similar to the gyroscope's other two axes, such as before and after the launch having an angular velocity of zero as well as the massive change in values during freefall at 100 minutes into the flight. One part that jumps out though is the almost oscillating line the graph follows during the bulk of the flight. This makes perfect sense considering the axis this graph is describing. The z-axis is pointing vertically, meaning the angular acceleration the gyroscope is measuring is from the rotation of the payload. Looking at the oscillations, the angular velocity increases and decreases in one direction for a short period then does the same thing but in the opposite direction. This is because the string supporting the payload wound itself up during the beginning of the flight. This winding made the payload rotate one way, unwinding the cord for a short time, but rewound it as well, then unwinded again in the opposite direction. This is similar to a yo-yo in many ways. When you release a yo-yo, it falls to the end of its string, unwinding itself. Once it hits the bottom, it rewinds itself up to the top. This cycle on our flight created an oscillating motion, where the angular velocity increased and decreased in one direction, and then reversed itself, doing the same thing but in the opposite direction.

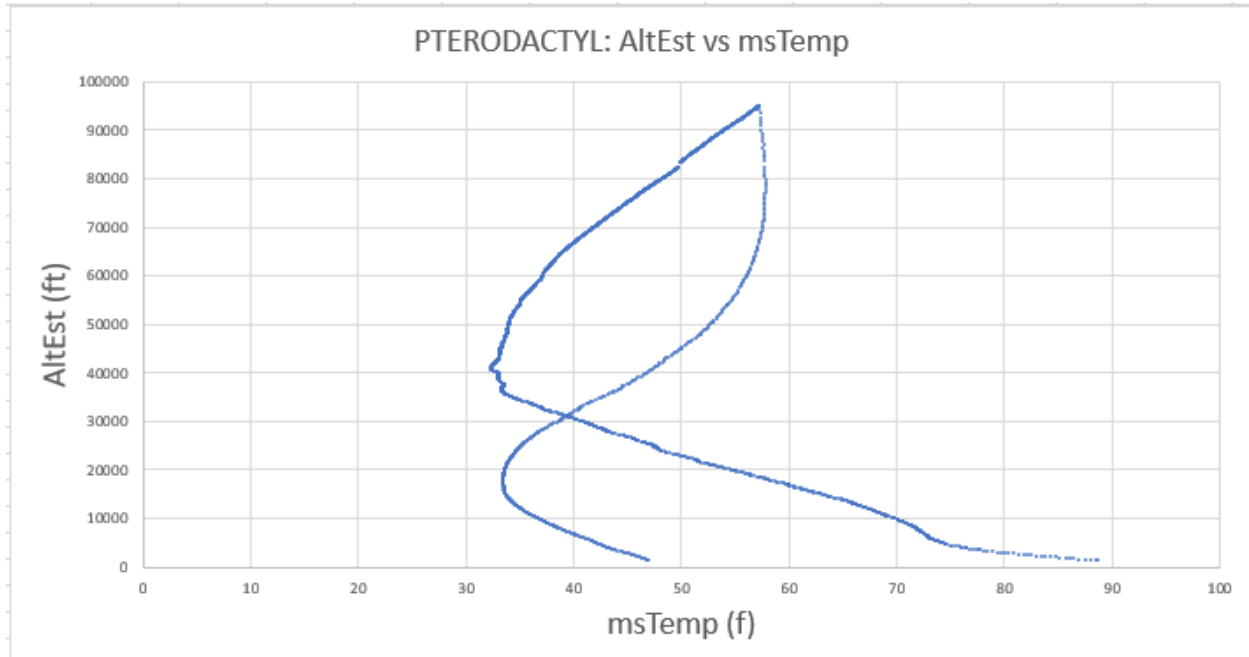

Shown above are the temperature readings taken by the PTERODACTYL unit onboard the payload. When initially looking at the graph it starts at the rightmost value of approximately 88 Fahrenheit and ends around 47 Fahrenheit. A possible explanation for the high temperature compared to the ambient temperature is that the area the sensor was situated in became hot because of the heat transferred by the sun. Following the dots, we see that the lowest record temperature by the PTERODACTYL was approximately 32.5 Fahrenheit, approximately 10 degrees colder than the payload's descent from the stratosphere. Another thing to note is that the payload read it was the coldest during the descent was about 20,000ft below the absolute minimum temperature read. One possible cause of this could be that the areas where the payload took off and landed had very differing temperatures causing this or something else. For reference, this data plot is started directly at the launch of the payload.

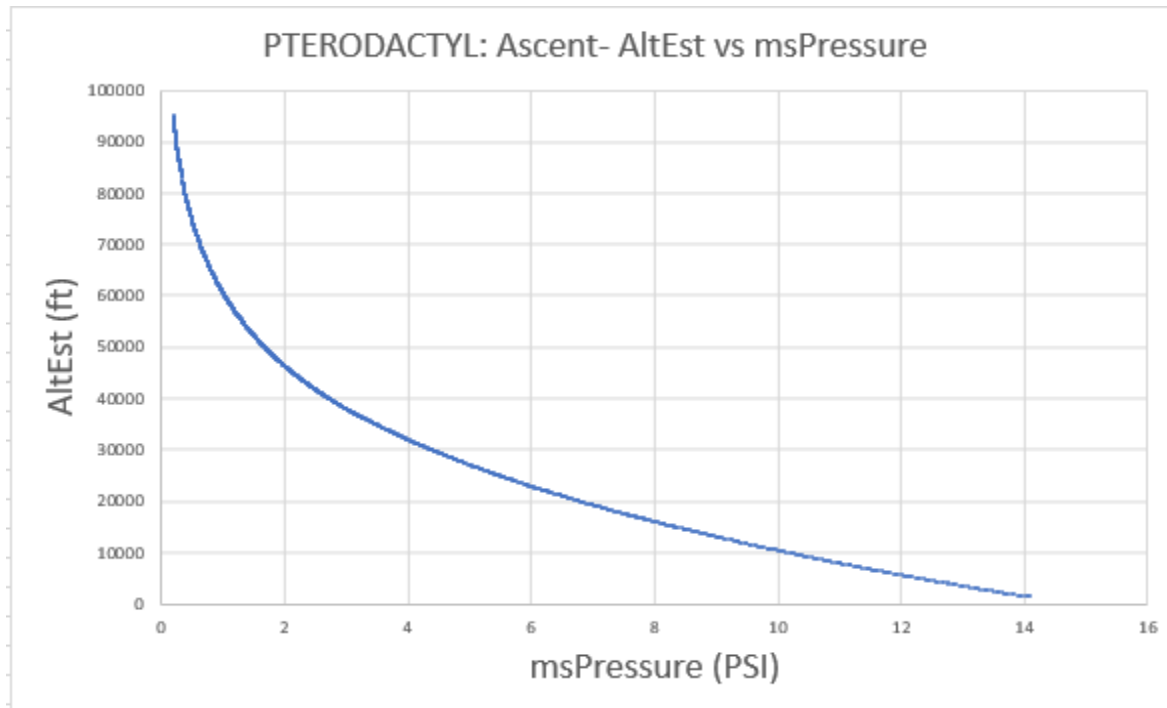

Shown above is the graph is the data plot where the pressure was tracked with respect to altitude during the payload's ascent into the stratosphere. The ambient air pressure is approximately 14.1PSI which is standard for being approximately 1,000ft above sea level. Following the data points left the pressure exponentially goes down as the altitude rises. The lowest pressure read was 0.21 PSI which is at the balloon's highest point.



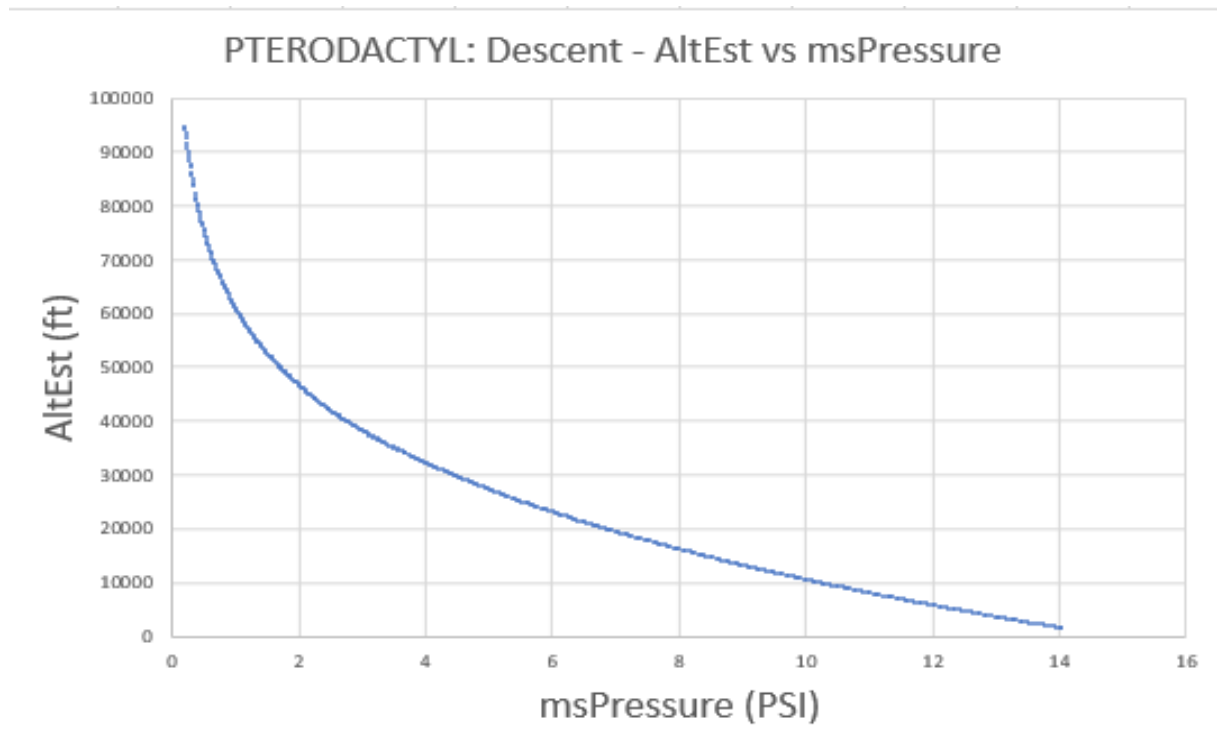

Shown above is the data plot of the pressure as it descends back into the thicker parts of the atmosphere from its highest point. Starting from the left the data plots are far apart enough to be individually seen unlike during the ascent plot. Overall there are less data points overall during the descent due to the high speed of the payload when falling it is possible to see the data points in most areas as well. As the payload descends the pressure of the air pressure of the launch and landing zones are effectively the same. This data could be used to help explain the cause of the extreme temperatures on the AltEst vs msTemp graph.

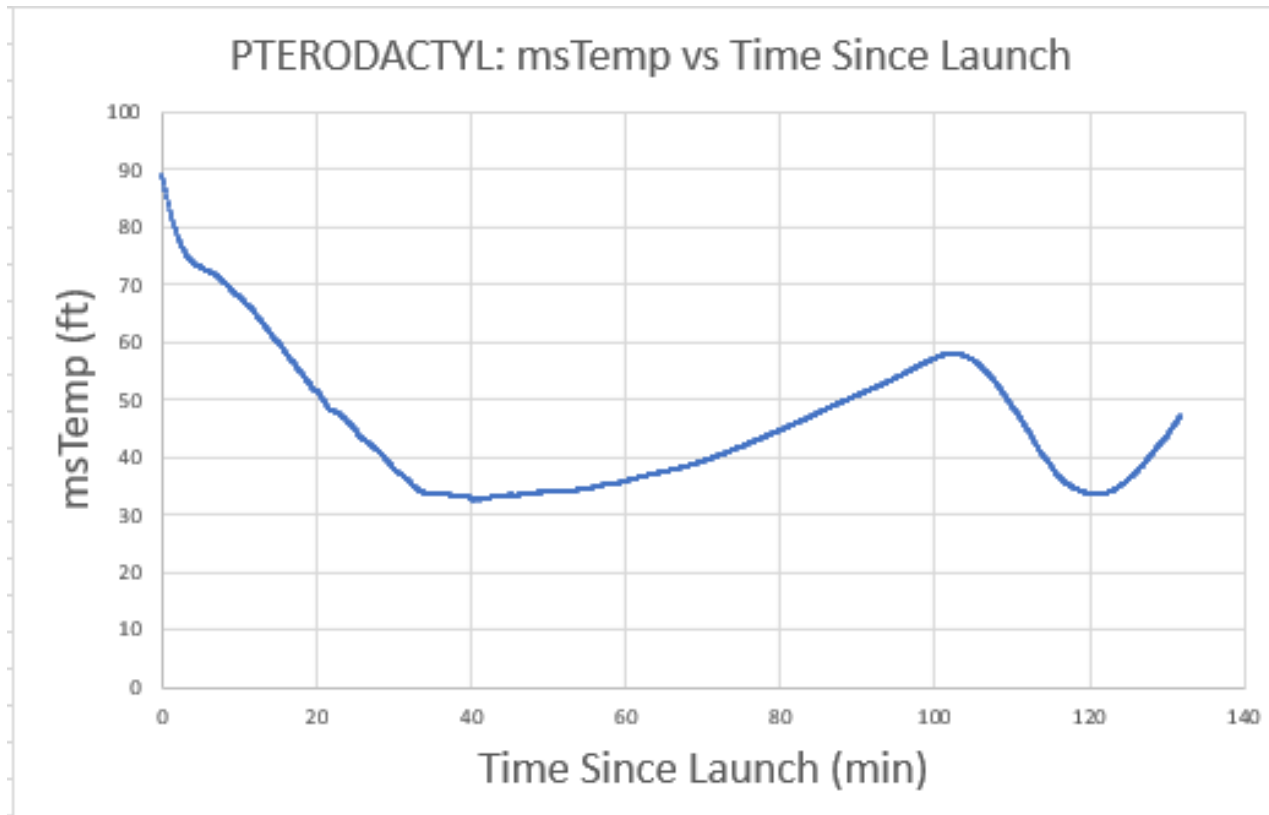

Shown above in the dataplot is the temperature read by the PTERODACTYL over the duration of time the payload was airborne. As seen in the other PTERODACTYL temperature plot the difference in the launch and landing temperatures is over 40 Fahrenheit. This shows more than likely the readings are due to the payload being heated up by the sun, or kept in a warm area as pressure didn't seem to be a factor as it stayed constant at the same altitude for launch and landing. The dip at 120 minutes though may of been caused by high winds going past the sensor causing it to get colder readings.

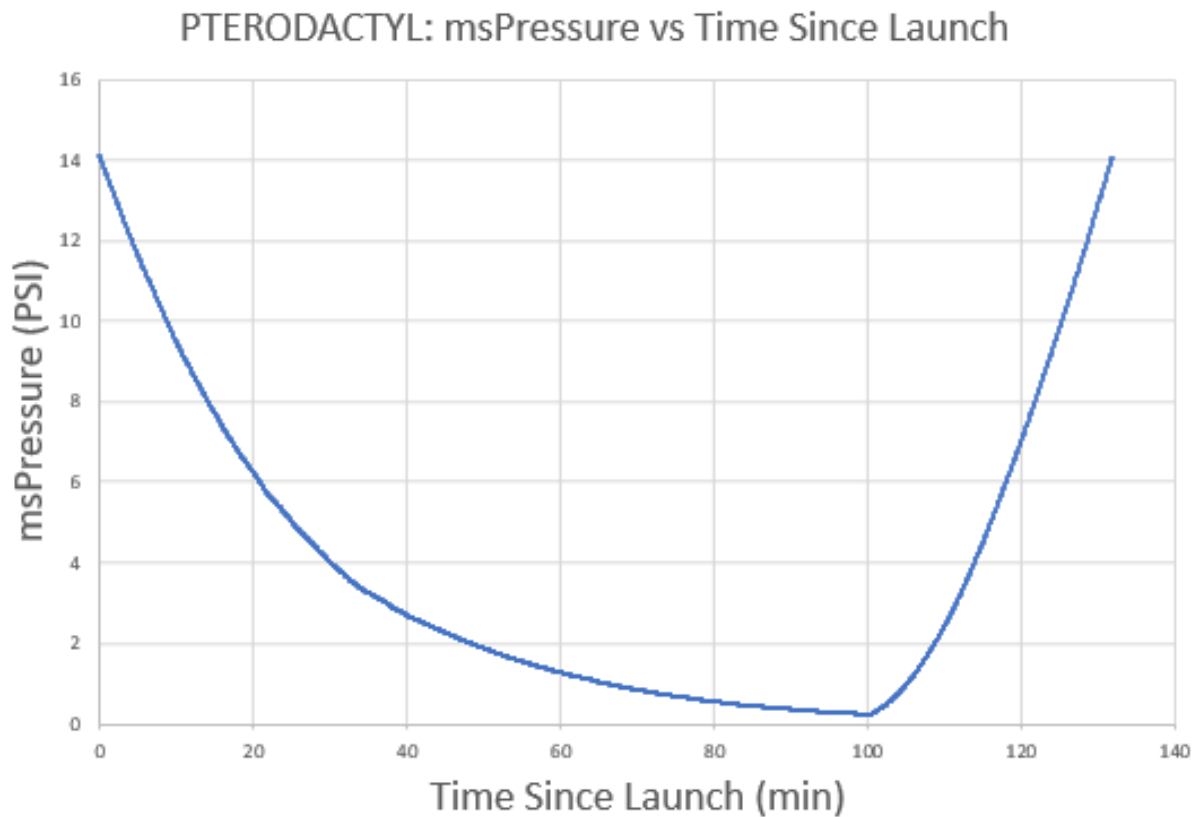

Shown above is the dataplot created from the pressure taken by the PTERODACTYL barometer with respect to the time since the launch in minutes. Here it shows a nice view of the pressure data collected by the barometer and allows one to more easily compare and contrast the ascent and descent of the payload through the pressure readings. We can see that approximately at 100 minutes the payload reached its maximum height as the pressure readings were at their lowest there.

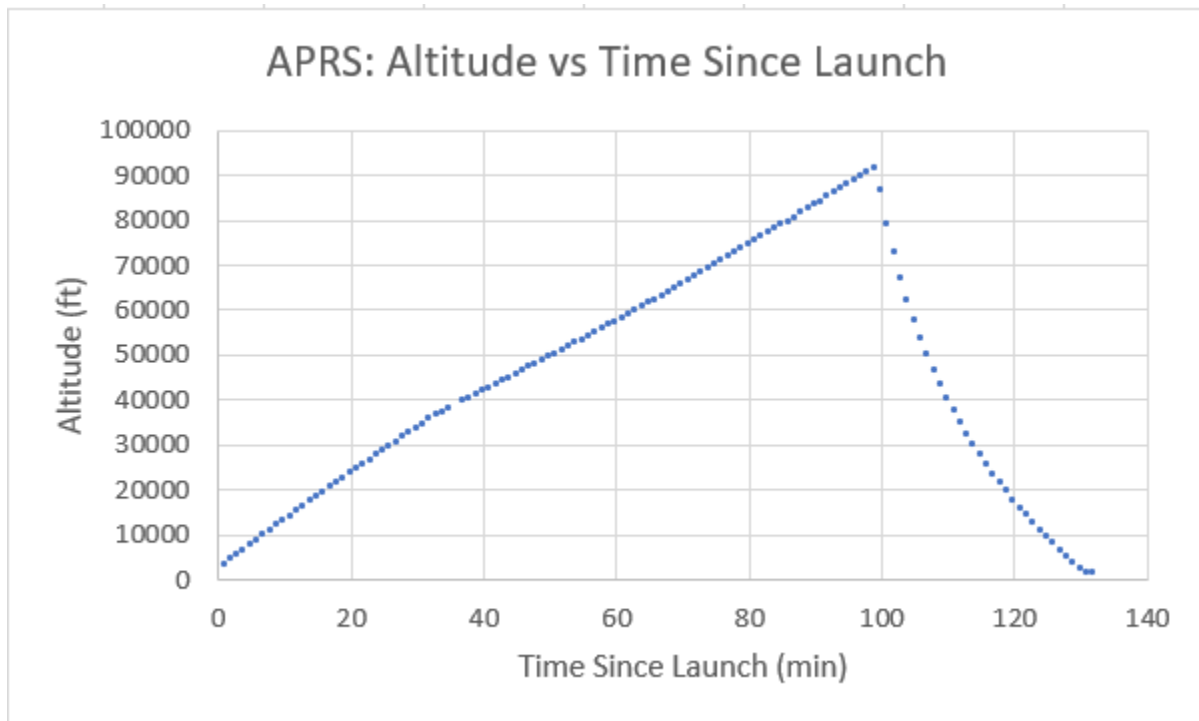

Shown in the graph above is a simple readout for the altitude vs the time since the launch in minutes. It makes it possible to compare this data with the pressure data and see major events and analyze them in further detail. For example with this we can see on both plots that at approximately 100 minutes after the launch the balloon reaches its maximum height a little above 90,000ft. And that it seems the payload touched down around 130 minutes after the launch.

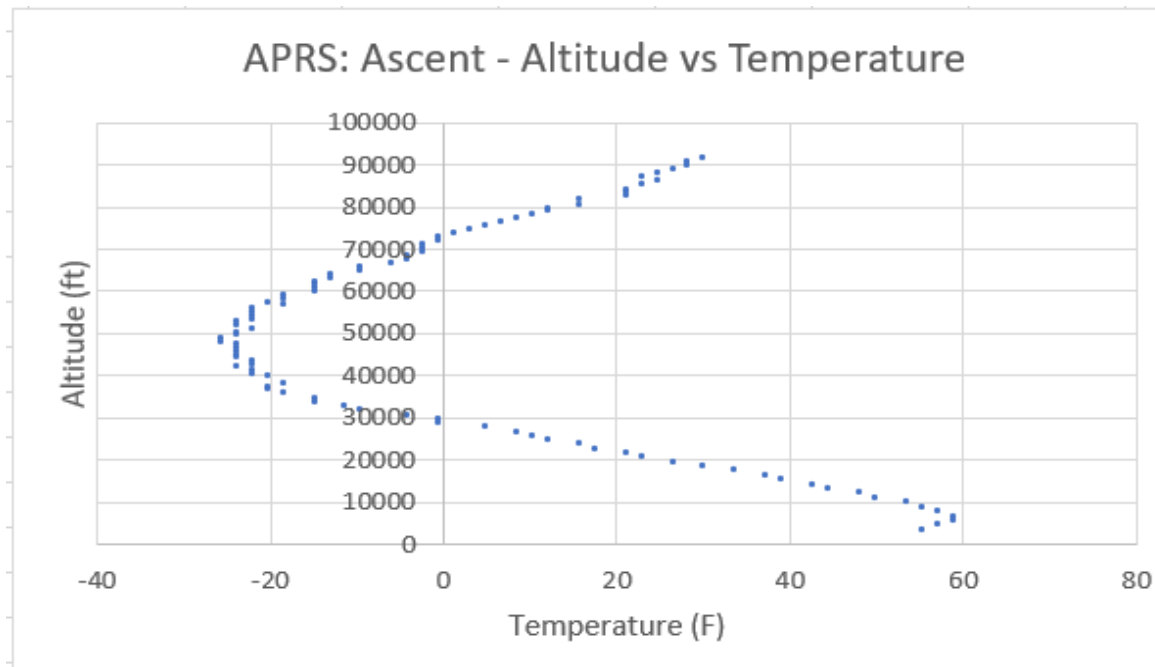

Shown in the graph above is the readout by the APRS for the temperature vs altitude for the balloon's ascent. We can see and compare it with the temperature data collected by the PTERODACTYL system and see that the initial temperature was more around 55 Fahrenheit instead of 90. Starting at the right and head left we see that the temperature data collected by the APRS dipped below -20 Fahrenheit, about 50 degrees lower than the lowest temperature collected by the PTERODACTYL. Though at the maximum altitude it is around 30 degrees, about 30 below what the PTERODACTYL read. This shows that one of the sensors isn't reading properly.

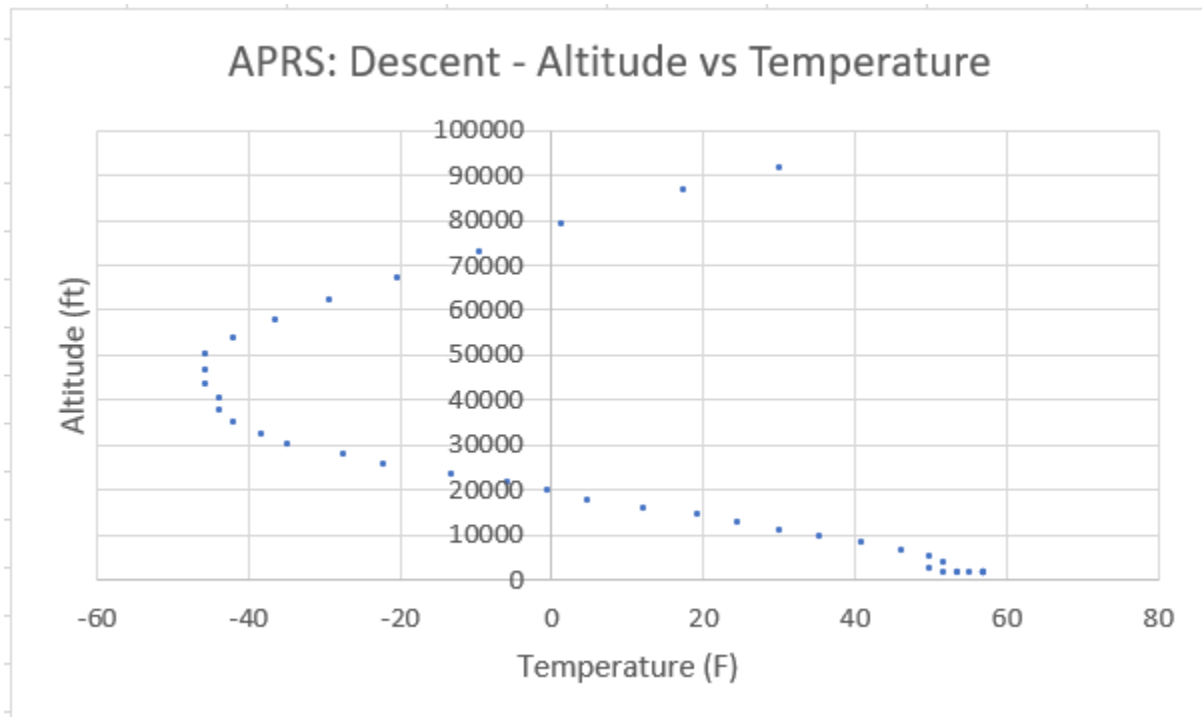

Shown above is the descent plot for the altitude vs temperature data collected by the APRS. We see that on the descent the temperature dips down much more, with it dropping to over -45 Fahrenheit. Though afterwards the general temperature curve for the descent is the same as the ascent, just more extreme.

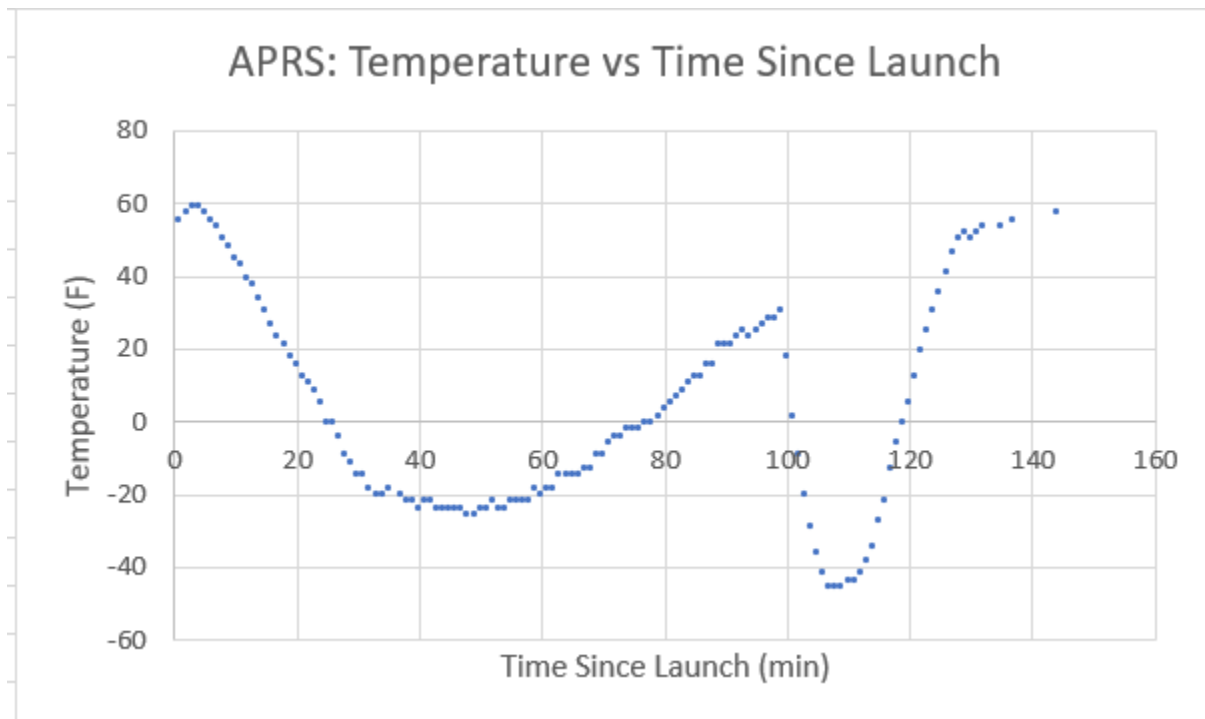

Shown above is the temperature data vs time since launch collected by the APRS and it gives a nice view of the last 2 graphs for comparison. One thing to notice is that temperature drops a lot at around 110minutes, and I am assuming as it hit a cold patch of air whilst falling very fast.

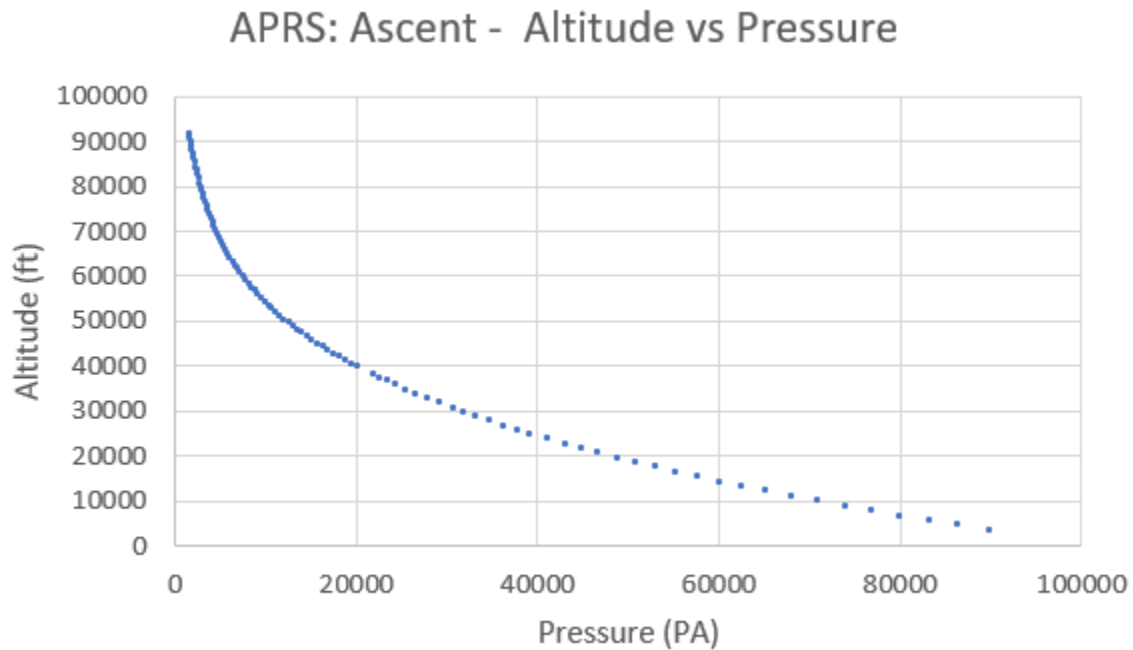

Shown above is the pressure data vs altitude collected by the APRS for the ascent of the payload and it is more or less the same exact curve as the PTERODACTYL. Here it allows us to get a general idea on the ascent profile of the payload. We can see the pressure increase and decrease exponentially with altitude.



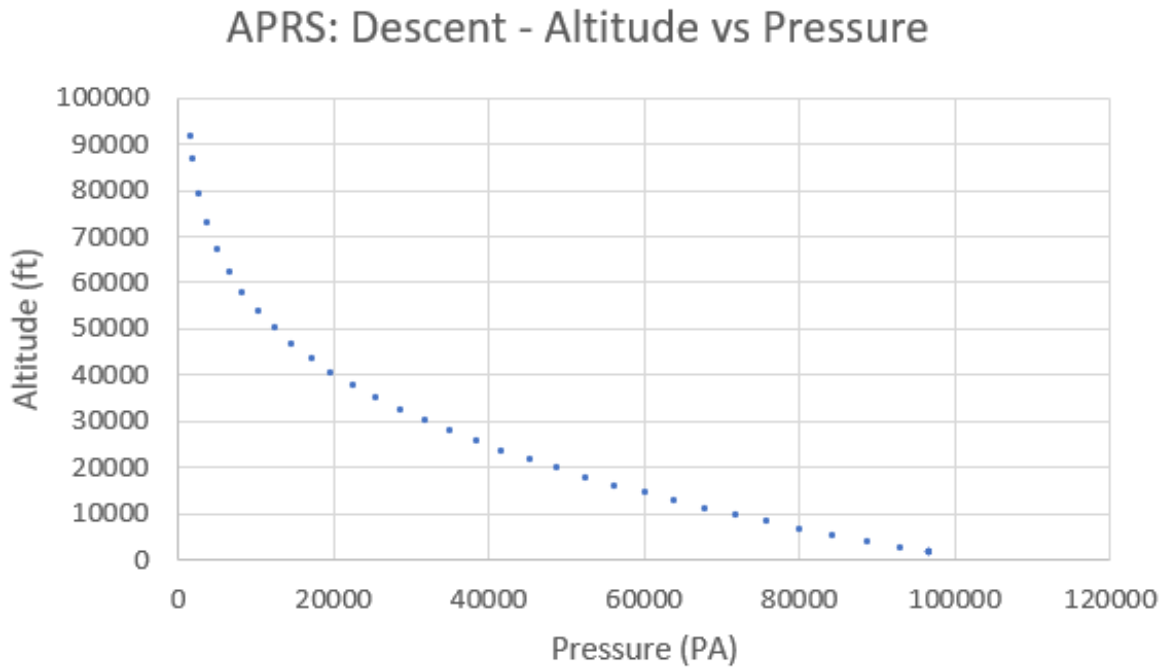

Shown above is the pressure data vs altitude collected by the APRS for the descent of the payload and it is more or less the same as its PTERODACTYL counterpart. We also see that during the descent that the payload is traveling much faster as shown by the increase in the distance between the dots.

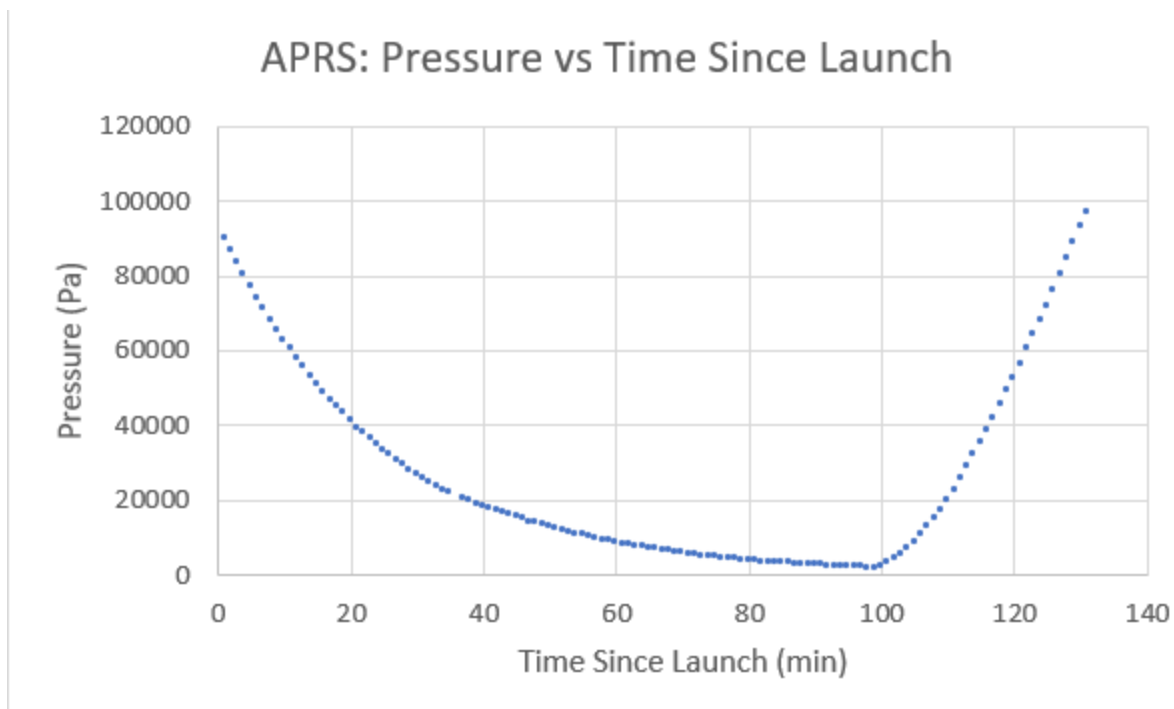

Shown above is the pressure data vs time since launch collected by the APRS for the total flight of the payload. When compared to the data collected by the PTERODACTYL and Neulog they are almost identical in shape. Here it shows that the maximum height represented by the minimum air pressure is around 100 minutes, which lines up with all the data collected by the PTERODACTYL and APRS.

Pictures from Video of Flight:



The picture above is immediately after launch, and the payload is already beginning to climb rapidly. The alarm can still be heard clearly, and a wide view of the horizon is visible for a great deal of the flight.



This is a picture of when the alarm to aid in retrieval cannot be heard anymore. This is due to the extremely low air pressure, or air density, which restricts the ease at which sound travels through the air. Judging by the time, this is at roughly 60,000 feet above sea level.

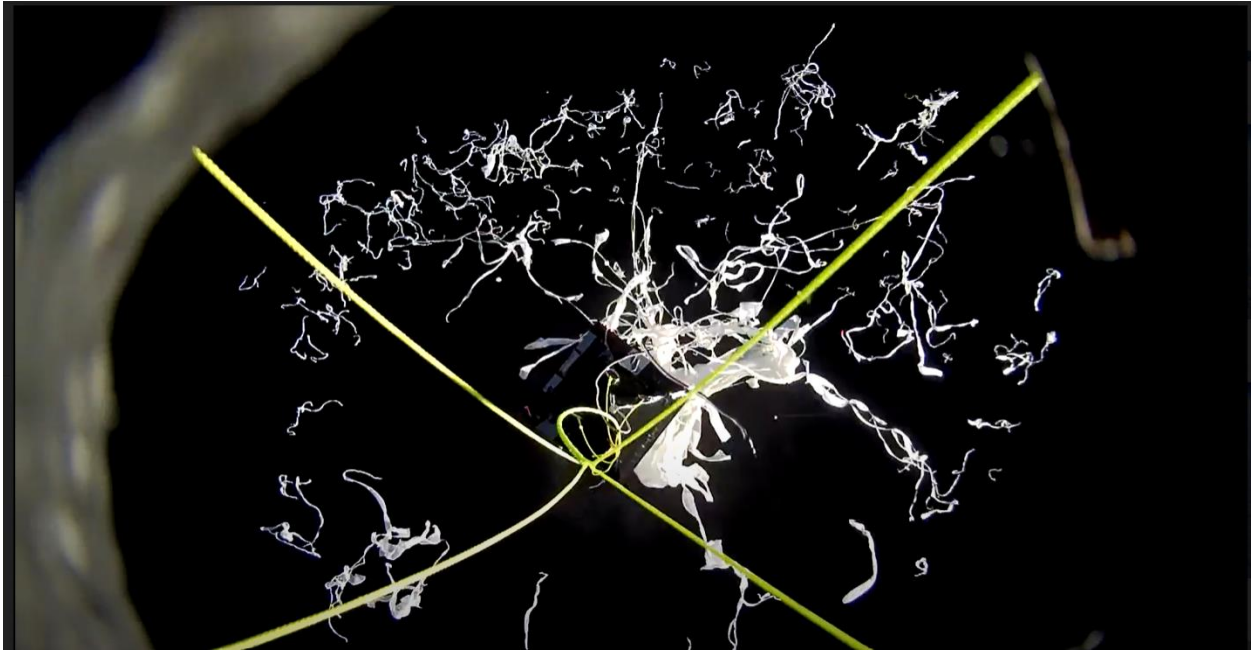

This picture was taken right after the balloon burst, captured from the payload looking up at the entire stack. It feels as though it's almost in slow motion, due to the extremely low pressures, making every stand still.



Here we have the view from our payload right before it landed. As one can probably tell, it was right into a tree, 60 feet off the ground. Without Professor Flaten's balloon retrieval device (a really long stick with a hook), we definitely would not have gotten our payload back that day.

## 11.0 Conclusions and Lessons Learned

As a reminder, our goal with this flight was to gain information on properties of solar power throughout the atmosphere and to collect contextual information that could help explain trends.

From looking at our solar panel current and voltage data we can assume that there is a trend for solar power with altitude up to 100,000 feet to initially become stronger, then weaken over time before becoming quickly stronger. This trend is most likely due to the change in layers of the atmosphere. Using our temperature from various sources and our pressure data we know that at roughly 30 mins we go through the tropopause. At this time the voltage and current both go from increasing to decreasing. This means we can assume that throughout the troposphere the solar power increases with altitude and throughout the stratosphere, the solar power decreases with altitude. This can be reasoned as the higher the altitude in the troposphere the fewer molecules of air or water there are to reflect or dissolve the sunlight. There were no clouds the day of launch, but if there were then we would have most likely seen a spike when the payload went past the cloud coverage. In the stratosphere, we get into the ozone layer which is densely packed full of ozone. This makes it hard for the solar panels to take in the sunlight and we see a decrease in solar power. The final peak of voltage and current is a little harder to explain. This happened when the balloon should have been falling. It could be that this spike was due to better visuals of the sun during the fall. The high and low nature of the voltage and current sensors was undoubtedly due to the rotation seen in gyroscope data and video. This high-low data is due to often only one solar panel facing the sun while the other points away. Interestingly the low and high voltage tends to follow opposite trends while the current was mostly parallel. The away solar panel produced decreasing voltage while the toward produced increasing voltage and vice versa. The dual nature of the voltage could give more credence to the dissolved/reflected light idea that was mentioned above. In the areas that have more dissolved/reflected light the one facing the sun would get less solar power than if no reflection and the one was facing away would get more than if there was no reflection. So as one gets more direct sunlight, the other gets less reflected sunlight. I do not know enough to understand why this dual nature did not happen to the current as well. However, because the two measurements do not agree with each other it makes me question any assumptions made from them. The temperature of the electronics could have played a big role in the trends found in the data, however, looking at our internal and external temperature graphs, the temperature was not an affecting factor. Our internal temperature stayed within operating temperature especially compared to the external temperature which could only be partially measured. This means that our attempts to prevent the cold from affecting our payload worked.

Some things for any future ballooners:

- Make sure your camera is well secure and in working order. One of ours dislodged after the balloon burst and the other stopped functioning close to touch down.
- Double check to make sure your code provides all details. Our code ended up with no locational data. Luckily others collected data that we could use.
- Have some fun with it and try to make something you're proud of. There is no scientific reason our payload was an upside down pyramid.

## 12.0 References

1. Cornwall, Chris. “Solar Position Calculator.” *NOAA Solar Position Calculator*, 8 Dec. 2002, [http://www2.arnes.si/~gljsentvid10/nebes\\_pod/legasonca.html](http://www2.arnes.si/~gljsentvid10/nebes_pod/legasonca.html). Accessed October 15th, 2021.
2. Verhage, L. Paul. “Amateur near Space Exploration: The Do-It-Yourself Space Program.” *Space 2002 and Robotics 2002*, 2002, [https://doi.org/10.1061/40625\(203\)38](https://doi.org/10.1061/40625(203)38). Accessed October 29th, 2021.
3. Sunrun, Team. “Do Solar Panels Work in Cold Weather?” *Sunrun*, Sunrun, 25 May 2021, <https://www.sunrun.com/go-solar-center/solar-articles/do-solar-panels-work-in-cold-weather>. Accessed November 3rd, 2021.
4. Ranjan, Manas. “Effect of Different Environmental Factors on Performance of Solar Panels.” *International Journal of Innovative Technology and Exploring Engineering*, vol. 8, no. 11, 2019, pp. 15–18., <https://doi.org/10.35940/ijitee.j9889.0981119>. Accessed November 4th, 2021.
5. “Change in the Atmosphere with Altitude.” *Change in the Atmosphere with Altitude / UCAR Center for Science Education*, 2013, <https://scied.ucar.edu/learning-zone/atmosphere/change-atmosphere-altitude>. Accessed November 3rd, 2021.

## 13.0 Program Listing

### Arduino:

The main criteria for the code was to have working code, be able to send down data every couple minutes, record all sensor values onto a sd card, add lines for the QWIK sensor, and add lines for our own added sensors. While writing the code, many problems appeared. For example, the QWIK sensor needed three drivers to run along with the code, which proved to be more complicated than expected. Another problem includes trying to understand the given code in order to know where to add the new code needed for the added sensors and data being sent down to the ground. The last example was finding times to trade off the payload so the code could be tested while the payload still needed work done on it. After what was thought to be the code done and complete, it is found that there was a line missing relating to the code that is being sent down to the ground. During launch day, before we left for the launch site, this was fixed and the code was now officially complete.

After the launch while the data was being analysed, it was noticed that the code did not record the time, date, latitude, and longitude. Also, the code seemed to record the altitude in an inconsistent way, making it hard to follow and almost unusable. Luckily, the other payload on the same stack had their data recorded well, so their data could be placed into the incomplete data.

### NeuLog Application:

The NeuLog Application is what we used to gather a majority of our data given the fact that we used five Neulog sensors. It allows experiments to be run on up to five different sensors in a chain at a time. It also is capable of running both online and offline experiments meaning that it can run experiments while the sensors are plugged in to a computer and it can collect data with preset conditions such as experiment length simply by connecting the sensors to a battery and turning the sensors.

### OnShape:

Onshape is a virtual designing software that allowed us to create the basic concepts and prototypes of our payload before we constructed it. It allowed us to place parts and modules within the box to figure out which orientation would work best for our payload. It also allowed us to display our payload to the class without wasting materials for a prototype.

### Microsoft OneNote (block diagram):

A program designed for taking notes and making basic drawings and sketches. I created the sketches using my Microsoft Surface Pen on the OneNote program.